

<b>06</b>	<b>ORG.BASE CADRES-SUSPENS.</b>
	FRAMES-SUSPENS-BASIC COMPONENT
	GRUNDORGAN RAHMEN-RADAUFHÄNG.

<b>66</b>	<b>ORGANE CADRES-SUSPENS.</b>
	FRAMES-SUSPENSIONS COMPONENT
	ORGAN RAHMEN-RADAUFHÄNGUNGEN

<b>222</b>	<b>CHASSIS UNIC 260 PORTEUR</b>
	UNIC 260 CARRIER CHASSIS
	FAHRGESTELL UNIC 260 L.K.W

VALIDITE DU  
TYPE D'ORGANE

COMPONENT  
APPLICABILITY

GÜLTIGKEIT  
DES  
ORGANTYPES

TYPE DE CHASSIS CHASSIS TYPE FAHRGESTELL TYP	N° DE CHASSIS CHASSIS Nr. FAHRGESTELL Nr.
<b>UNIC 260 P</b>	<b>402.001</b>

<b>06</b>	<b>66</b>	<b>222</b>	N° EDITION CATALOGUE	N° DE PLANCHE
1	2	3	4	5

Cadre de châssis .....	00	01
<i>Chassis frame</i>		
<i>Fahrgestellrahmen</i>		
Suspension avant .....	00	02
<i>Front suspension</i>		
<i>Vorderradaufhängung</i>		
Suspension arrière .....	00	03
<i>Rear suspension</i>		
<i>Hinterradaufhängung</i>		
Suspension arrière .....	00	04
<i>Rear suspension</i>		
<i>Hinterradaufhängung</i>		

1	ORGANE DE BASE	BASIC COMPONENT	GRUND-ORGAN
2	ORGANE	COMPONENT	ORGAN
3	TYPE D'ORGANE	COMPONENT TYPE	ORGANTYP
4	N° EDITION	CATAL. EDITION NUMBER	NUMMER DER AUSGABE
5	N° PLANCHE	PLATE NUMBER	BILD Nr.
6	REPERE	MARKING	KENNZIFFER

7	N° PIECE	PART N°	TEIL Nr.
8	DESIGNATION	DESIGNATION	BESCHRIFTUNG
9	QUANTITE	QUANTITY	MENGE
10	CODE OBSERVATIONS	CODE OF OBSERV.	ANMERKUNGEN KODE
11	DETAILS OBSERVATIONS	DETAILS OF OBSERV.	ANMERKUNGEN BEDEUT.

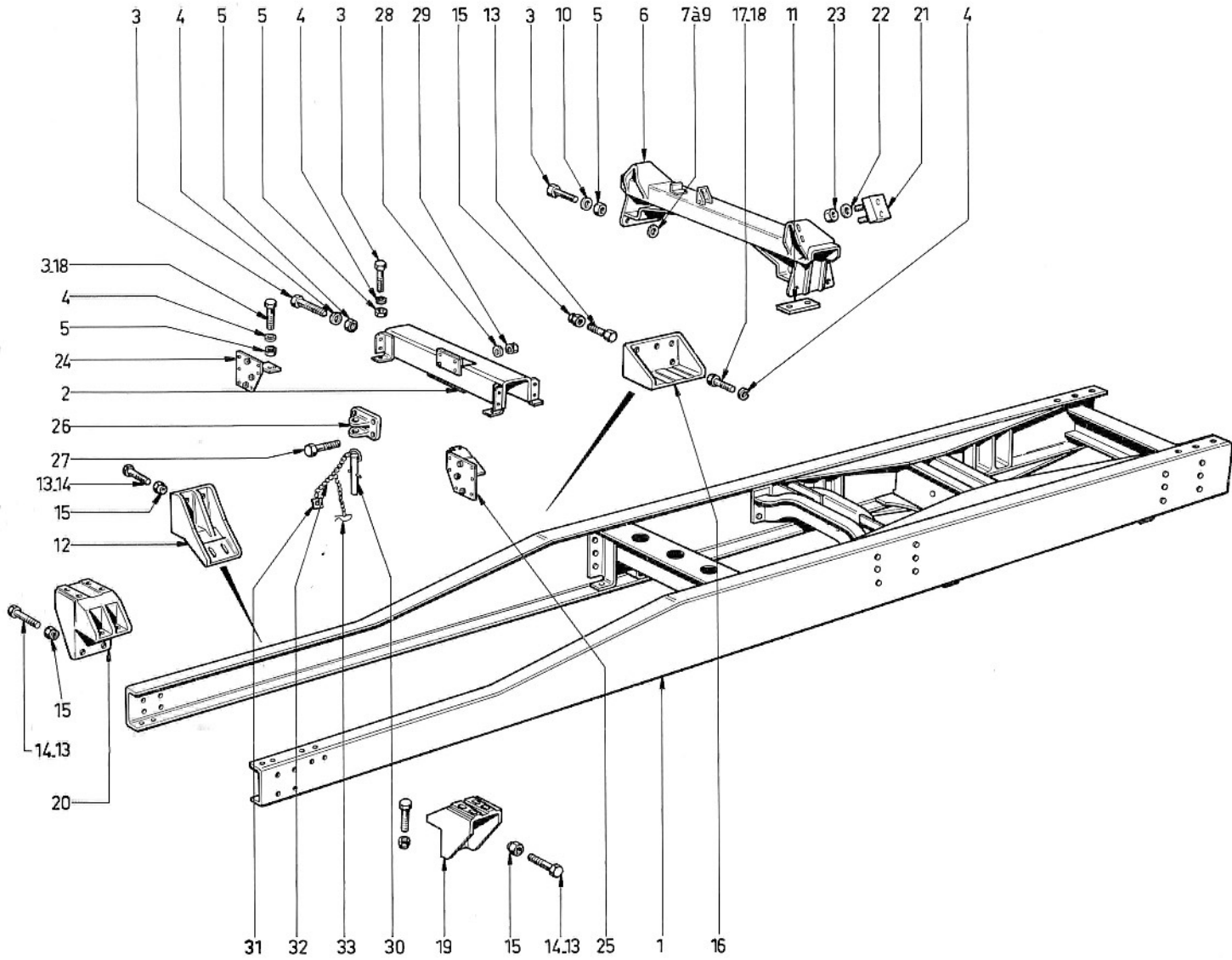

<b>06</b>	<b>66</b>	<b>222</b>	<b>00</b>	<b>01</b>
1	2	3	4	5

6	7	8	9	10
1	61673057	CHASSIS	1	
2	61667420	TRAVERSE AV	1	
3	61803190	VIS	20	
4	61815226	RONDELLE	28	
5	61801013	ECROU	32	
6	61667477	TRAVERSE	1	
7	61238487	RONDELLE		68
8	61238494	RONDELLE		68
9	61238495	RONDELLE		68
10	61815247	RONDELLE	10	
11	61576163	PLAQUE	2	
12	61233803	SUPPORT AV	2	
13	61803191	VIS	12	
14	61803193	VIS	3	
15	61801355	ECROU	19	
16	61238293	SUPPORT AR	2	
17	61803187	VIS	2	
18	61803189	VIS	15	
19	61237889	SUPPORT AV G	1	
20	61237888	SUPPORT AV D	1	
21	61235439	SUPPORT ELASTI	2	
22	61815040	RONDELLE	4	
23	61801354	ECROU	4	
24	61235463	SUPPORT D	1	
25	61235464	SUPPORT G	1	

6	7	8	9	10
26	61217007	CHAPE	1	
27	61803273	VIS	4	
28	61815249	RONDELLE	4	
29	61801015	ECROU	4	
30	61671981	AXE ASS	1	
31	61128056	PLAQUETTE	1	
32	61578416	CHAINE	1	
33	61127450	GOUPILLE	1	

10	11
----	----

68	Quantités : au choix Quantities : as desired Mengen : nach Wahl
----	---

10	11
----	----

--	--

**06 66 222 00 02**

DÉSIGNATION PLANCHE : SE RÉFÉRER AUX PAGES "SOMMAIRE"

PLATE DESIGNATION : REFER TO FLYLEAF

BILDBESCHRIFTUNG : SIEHE VORSATZBLÄTTER



6	7	8	9	10
1	61239276	MAIN	4	
2	61234546	CALE	2	
3	61803272	VIS	12	
4	61803274	VIS	4	
5	61801357	ECROU	15	
6	61668635	JUMELLE ASS	2	
7	61231505	BAGUE	2	
8	61220446	AXE	6	
9	61802696	VIS	6	
10	61815226	RONDELLE	6	
11	61801013	ECROU	6	
12	61836015	GRAISSEUR	1	
13	61836035	GRAISSEUR	5	
14	61217184	SUPPORT DROIT	1	
15	61217186	SUPPORT GAUCHE	1	
16	61239869	BUTEE	2	
17	61116500	ETRIER	4	
18	61580491	CALE	2	
19	61400070	ECROU	8	
20	61400072	ECROU	8	
21	61668634	RESSORT ASS	2	
22	61573693	LAME 1	2	
23	61239271	LAME 2	2	
24	61239272	LAME 3	2	
25	61239273	LAME 4	2	

6	7	8	9	10
26	61573698	LAME 5	2	
27	61573699	LAME 6	2	
28	61573700	LAME 7	2	
29	61573701	LAME 8	2	
30	61573702	LAME	2	
31	61212754	ETOQUE AU	2	
32	61115885	RONDELLE	2	
33	61115886	RONDELLE	2	
34	61425033	ECROU	2	
35	61223911	BRIDE	4	
36	61211827	BRIDE	4	
37	61408373	RIVET	4	
38	61211829	ENTRETOISE	4	
39	61575543	AXE	4	
40	61803285	AXE	4	
41	61575544	ECROU	4	
42	61801015	ECROU	4	
43	61231355	BAGUE	4	
44	61663346	AMORTISSEUR G	1	
45	61663347	AMORTISSEUR D	1	
46	61801191	VIS	8	
47	61801355	ECROU	8	
48	61669063	BIELLE G ASS	1	
49	61669064	BIELLE D ASS	1	
50	61704484	ECROU	4	

10	11

10	11

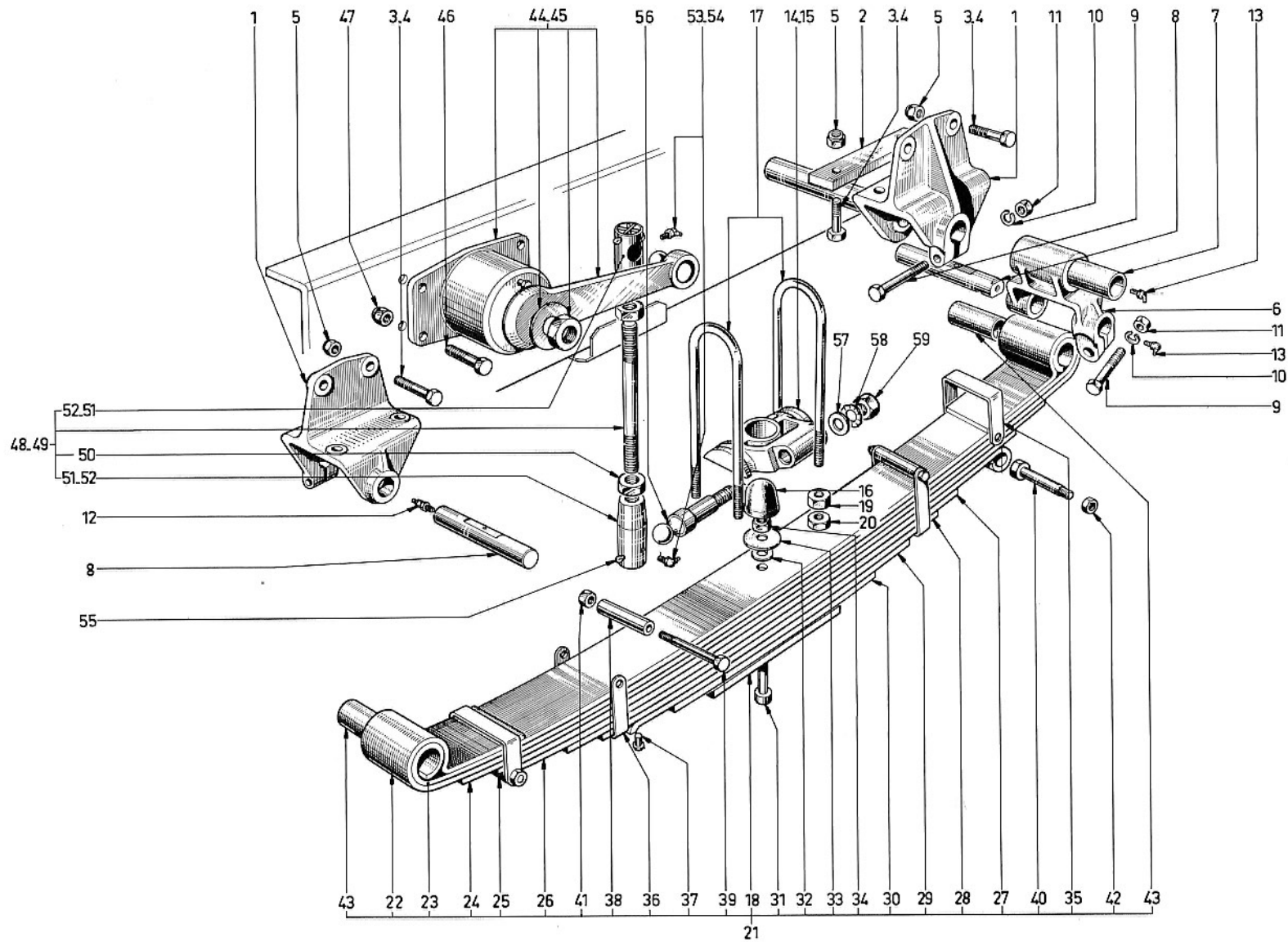

<b>06</b>	<b>66</b>	<b>222</b>	<b>00</b>	<b>02</b>
1	2	3	4	5

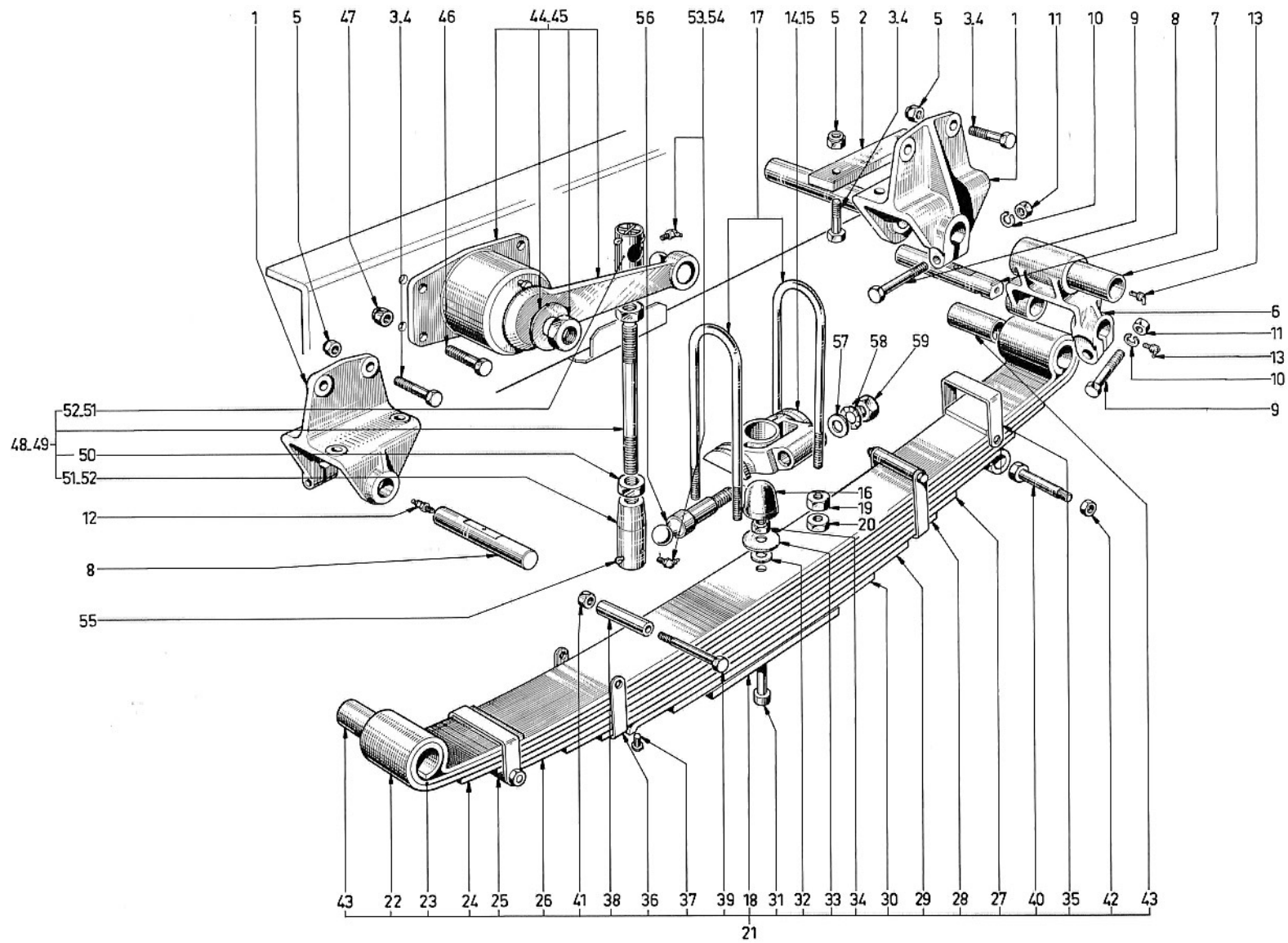

<b>06</b>	<b>66</b>	<b>222</b>	<b>00</b>	<b>02</b>
1	2	3	4	5

6	7	8	9	10
51	61701598	BOITE ROTULE G	2	
52	61701599	BOITE ROTULE D	2	
53	61410514	GRAISSEUR	2	
54	61410502	GRAISSEUR	2	
55	61819933	GOUPILLE	4	
56	61573695	ROTULE	2	
57	61815010	RONDELLE	2	
58	61400964	RONDELLE	2	
59	61801070	ECROU	2	

6	7	8	9	10

10	11

10	11

**06 66 222 00 03**

DÉSIGNATION PLANCHE : SE RÉFÉRER AUX PAGES "SOMMAIRE"

PLATE DESIGNATION : REFER TO FLYLEAF

BILDBESCHRIFTUNG : SIEHE VORSATZBLÄTTER

camions  
**UNIC**  
**FIAT**

1	2	3	4	5	
6	7	8		9	10
1	8788098	ETRIER		2	
2	8788102	PLAQUETTE		4	
3	8787821	PLAQUETTE		2	
4	15982530	VIS		12	
5	10517270	FREIN		12	
6	12164121	ECROU		12	
7	8788099	ETRIER		2	
8	8527975	SUPPORT		4	
9	8787818	PATIN		4	
10	38529949	VIS		16	
11	10054210	FREIN		16	
12	12164411	ECROU		16	
13	895507	ECROU		10	
14	895508	GOUPILLE		10	
15	8787813	SUPPORT		2	
16	895674	RONDELLE		8	
17	8527947	ECROU		8	
18	13407211	GRAISSEUR		2	
19	8787558	DOUILLE		4	
20	8550307	RONDELLE			68
21	8550308	RONDELLE			68
22	8550312	BAGUE		2	
23	8550365	JOINT		2	
24	8550304	COUVERCLE		2	
25	11198071	RONDELLE		20	

6	7	8	9	10
26	16043421	VIS		20
27	38550310	FREIN		4
28	38550309	VIS		8
29	4549458	RENIFLARD		2
30	8787770	RESSORT ASS		2
31	8787771	LAME 1		2
32	8787772	LAME 2		2
33	8787773	LAME 3		2
34	8787774	ETRIER		4
35	8787776	ENTRETOISE		4
36	8787775	AXE		4
37	16102311	ECROU		4
38	12164111	ECROU		2
39	8787823	AXE		2
40	8534477	CABLE		4
41	8534481	RONDELLE		8
42	8554200	RONDELLE		8
43	8534479	TAMPON		16
44	8554199	RONDELLE		16
45	12164211	ECROU		8
46	10726611	ECROU		8
47	8787816	ETRIER		4
48	8787817	SUPPORT		2
49	8787815	RONDELLE		4
50	895676	VIS		4

10	11
68	Quantités : au choix Quantities : as desired Mengen : nach Wahl

10	11

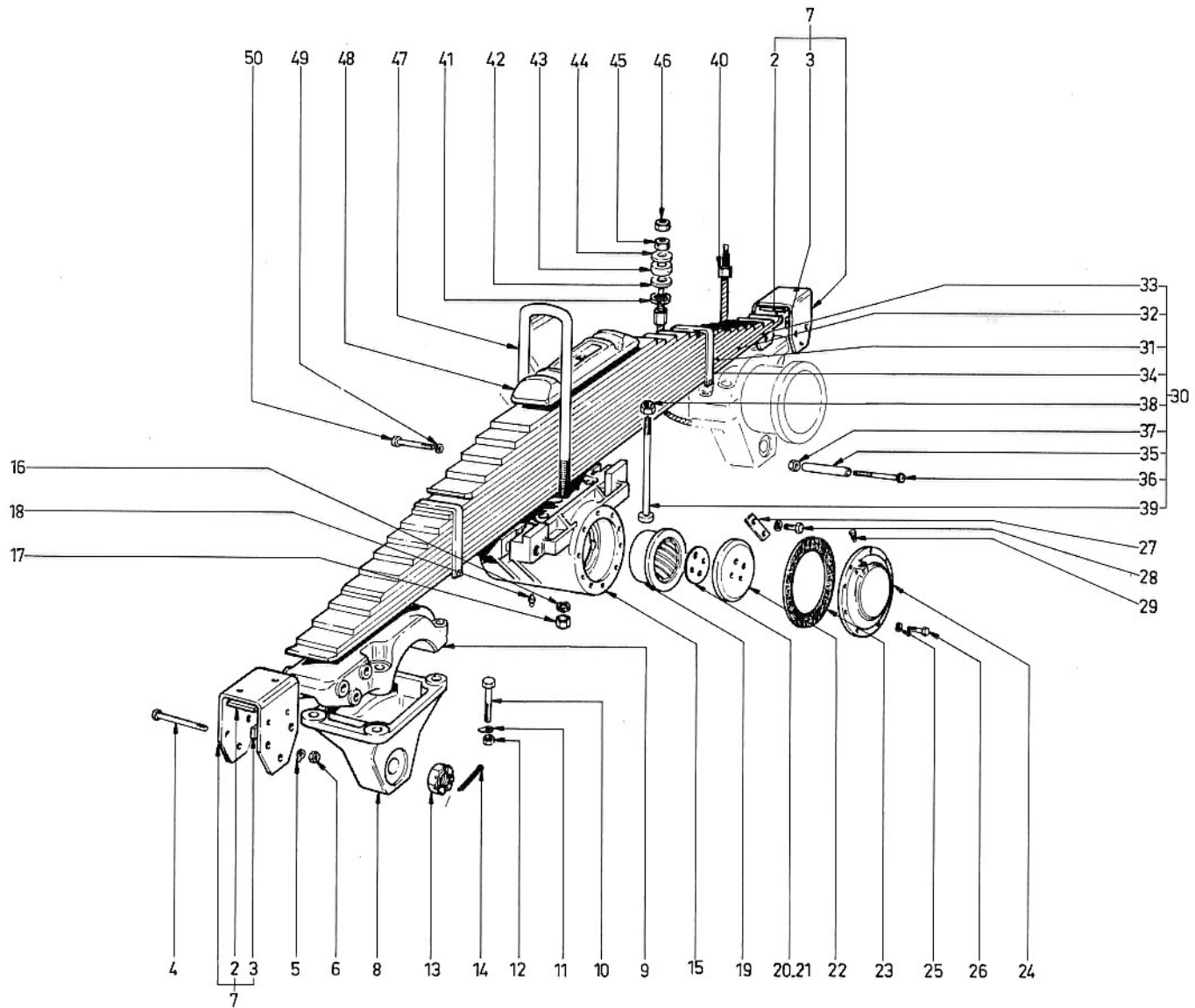

<b>06</b>	<b>66</b>	<b>222</b>	<b>00</b>	<b>03</b>
1	2	3	4	5

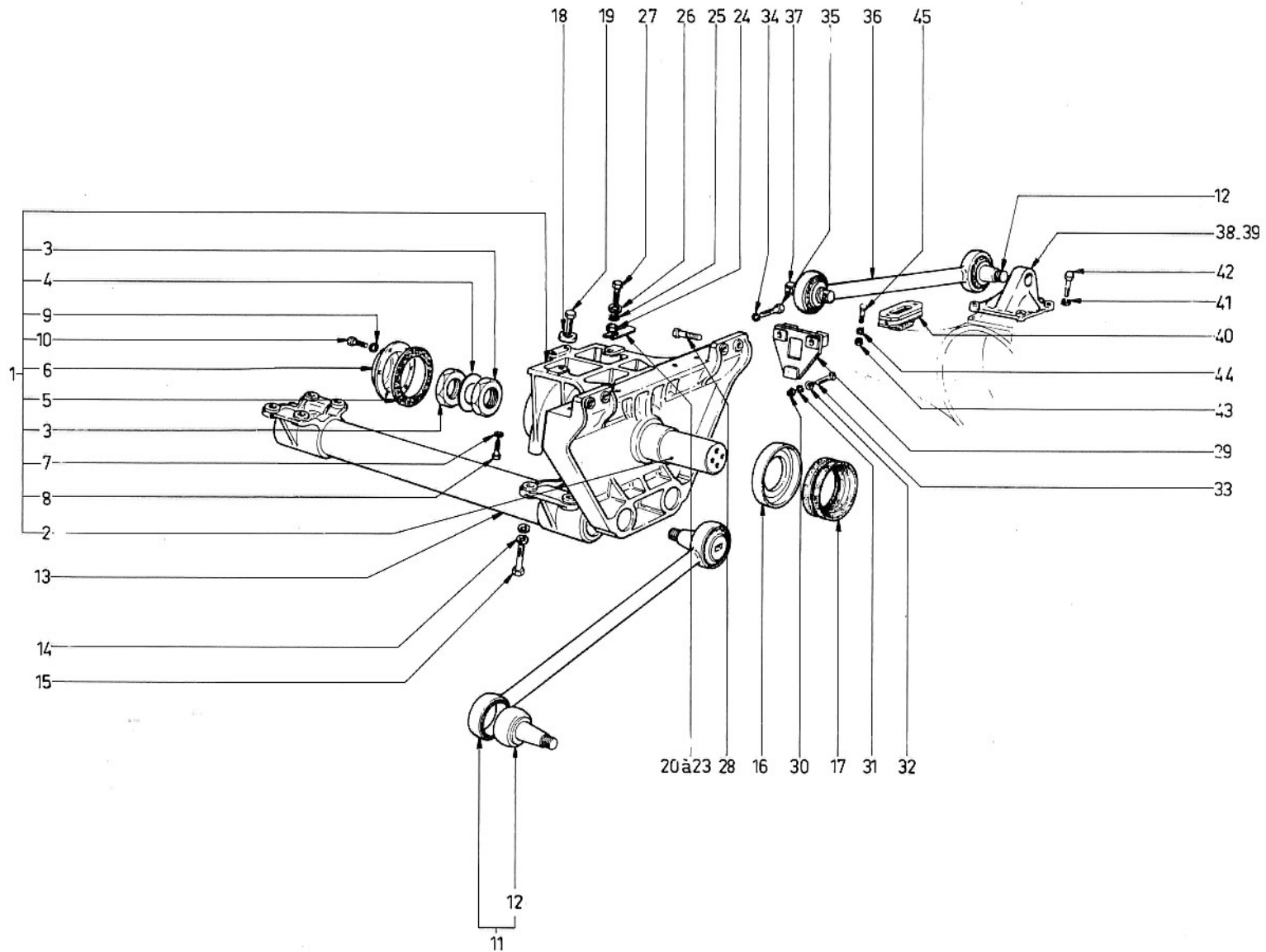

06	66	222	00	04
1	2	3	4	5

6	7	8	9	10
1	8787825	SUPPORT ASS	1	
2	8550303	ARBRE	1	
3	895697	ECROU	2	
4	895698	RONDELLE	1	
5	4601704	JOINT	1	
6	4605849	COUVERCLE	1	
7	10517670	RONDELLE	1	
8	8527966	VIS	1	
9	11198071	RONDELLE	6	
10	16043221	VIS	5	
11	8529889	TIRANT ASS	4	
12	8529884	AXE	5	
13	8787810	ARBRE	1	
14	11200273	RONDELLE	8	
15	15981021	VIS	8	
16	8550311	BAGUE	2	
17	592553	JOINT	2	
18	8527990	RONDELLE	16	
19	15981221	VIS	8	
20	8528035	CALE EP 010		68
21	8554005	CALE EP 020		68
22	8554006	CALE EP 050		68
23	8554007	CALE EP 1		68
24	12164111	ECROU	28	
25	10517270	RONDELLE	28	

6	7	8	9	10
26	8787826	RONDELLE	4	
27	15981321	VIS	12	
28	15981021	VIS	8	
29	8787800	SUPPORT	2	
30	12164021	ECROU	2	
31	10517170	RONDELLE	2	
32	10520101	RONDELLE	2	
33	15977933	VIS	2	
34	11200473	RONDELLE	4	
35	38788105	VIS	4	
36	8787812	TIRANT	2	
37	8787768	AXE	1	
38	8787798	SUPPORT AV	1	
39	8787799	SUPPORT AR	1	
40	8529786	FLEXIBLOC	4	
41	11200473	RONDELLE	8	
42	38788104	VIS	8	
43	12164711	ECROU	16	
44	11198373	RONCELLE	16	
45	11234721	VIS	16	

10 11

68 Quantités : au choix  
Quantities : as desired  
Mengen : nach Wahl

10 11