

**06****ORG. BASE CADRES-SUSPENS.**

FRAMES-SUSPENSIONS BASIC COMPONENT

GRUNDORGAN RAHMEM-RADAUFHANGUNG

**66****ORGANE CADRES-SUSPENSIONS**

FRAMES-SUSPENSIONS COMPONENT

ORGAN RAHMEN-RADAUFHANGUNG

**218****C.S.A. « BIG-JOB » CHASSIS 4 x 4**

« BIG-JOB » CAB CHASSIS 4 x 4

« BIG-JOB » FAHRGESTELL 4 x 4

**06****66****218**n° édition  
cataloguen° de  
planche

1

2

3

4

5

Cadre de châssis . . . . .	00	01
<i>Frame</i>		
<i>Rahmen</i>		
Suspension avant . . . . .	00	02
<i>Front suspension</i>		
<i>Vorderradaufhängung</i>		
Suspension arrière . . . . .	00	03
<i>Rear suspension</i>		
<i>Hinterradaufhängung</i>		

VALIDITE DU  
TYPE D'ORGANECOMPONENT  
APPLICABILITYGÜLTIGKEIT  
DES  
ORGANTYPES

TYPE DE CHASSIS CHASSIS TYPE FAHRGESTELL TYP	N° DE CHASSIS CHASSIS N° FAHRGESTELL Nr.
27 - 44 T	290.010

1	ORGANE DE BASE	BASIC COMPONENT	GRUND-ORGAN
2	ORGANE	COMPONENT	ORGAN
3	TYPE D'ORGANE	COMPONENT TYPE	ORGANTYP
4	N° ÉDITION	CATAL. EDITION NUMBER	NUMMER DER AUSGABE
5	N° PLANCHE	PLATE NUMBER	BILD Nr.
6	REPÈRE	MARKING	KENNZIFFER

7	N° PIÈCE	PART N°	TEIL Nr.
8	DÉSIGNATION	DESIGNATION	BESCHRIFTUNG
9	QUANTITÉ	QUANTITY	MENGE
10	CODE OBSERVATIONS	CODE OF OBSERV.	ANMERKUNGEN KODE
11	DÉTAILS OBSERVATIONS	DETAILS OF OBSERV.	ANMERKUNGEN BEDEUT.

IMPRIMÉ EN FRANCE  
IMP. GERBOS - PARISReference 655.807  
Kennzahl  
EDITION 15/10/73  
AUSGABE

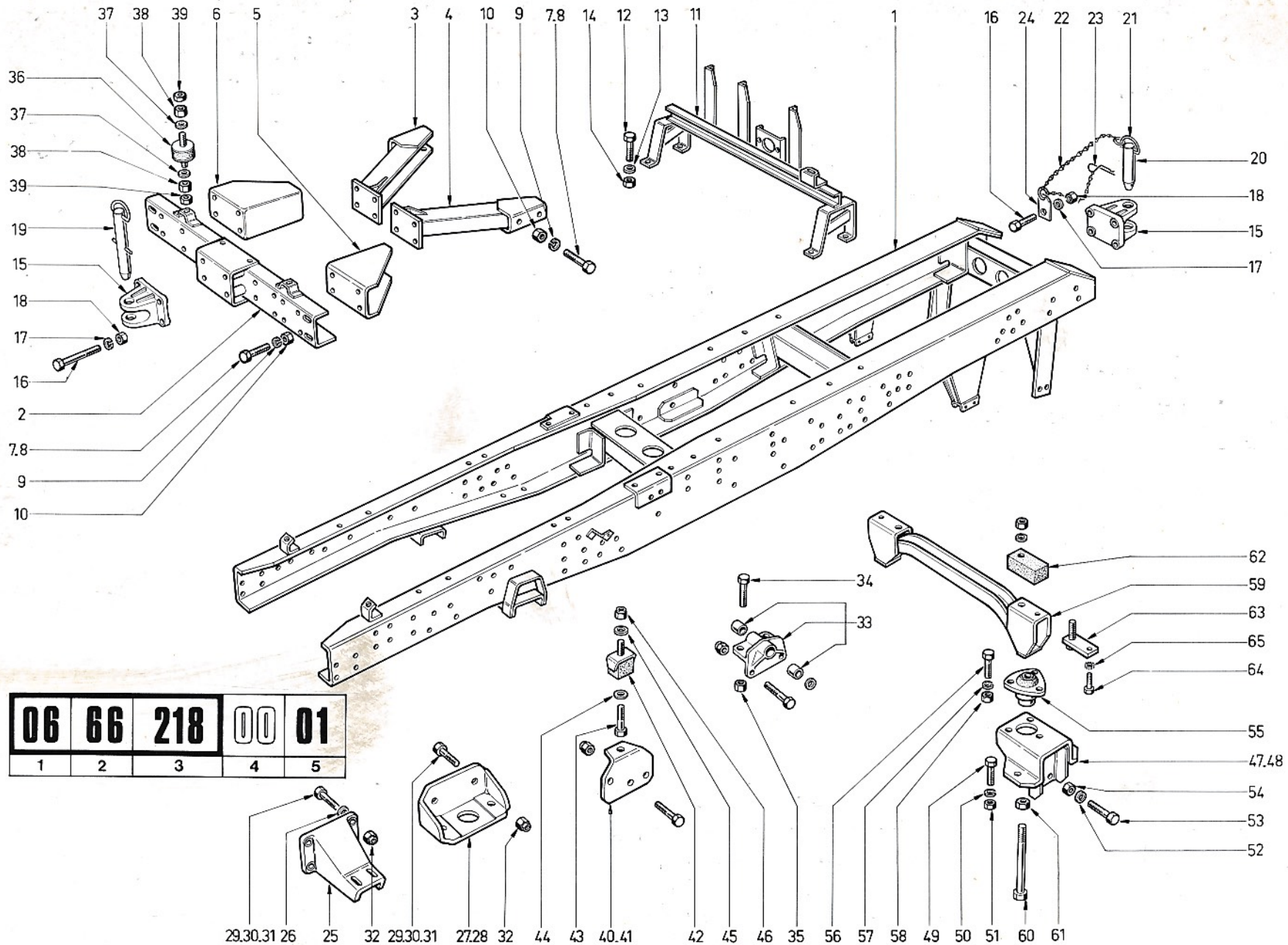

<b>06</b>	<b>66</b>	<b>218</b>	<b>00</b>	<b>01</b>
1	2	3	4	5

6	7	8	9	10
1	61675206	CADRE	1	
2	61657954	TRAVERSE	1	
3	61224691	TIRANT D	1	
4	61224692	TIRANT G	1	
5	61216667	GOUSSET G	1	
6	61216666	GOUSSET D	1	
7	61803190	VIS LON 35	4	
8	61803189	VIS LON 30	26	
9	61815247	RONDELLE	30	
10	61801013	ECROU	30	
11	61658084	TRAVERSE	1	
12	61802647	VIS	4	
13	61815306	RONDELLE	4	
14	61801012	ECROU	4	
15	61225968	CHAPE	2	
16	61803283	VIS	8	
17	61815249	RONDELLE	8	
18	61801015	ECROU	8	
19	61657953	AXE	1	
20	61226258	AXE	1	
21	61127449	ANNEAU	1	
22	61128100	CHAÎNE	1	
23	61127450	COUPILLE	1	
24	61128056	PLAQUETTE	1	
25	61220084	SUPPORT AV	2	

10	11

6	7	8	9	10
26	61226140	ENTRETOISE	8	
27	61232638	SUPPRT AR D	1	
28	61232639	SUPPRT AR G	1	
29	61803191	VIS LCN 40	4	
30	61803192	VIS LGN 45	5	
31	61803193	VIS LON 50	4	
32	61801355	ECROU	18	
33	61666378	SUPPRT PEDALI	1	
34	61803191	VIS	4	
35	61801355	ECROU	4	
36	61234244	PLGT	2	
37	61815040	RONDELLE	4	
38	61801012	ECROU	4	
39	61801705	ECROU	4	
40	61230759	APPUI G	1	
41	61230760	APPUI D	1	
42	61254889	SUPPORT	2	
43	61803187	VIS	2	
44	61815307	RONDELLE	2	
45	61238496	RONDELLE	2	
46	61801355	ECROU	2	
47	61235448	SUPPRT G	1	
48	61239164	SUPPORT D	1	
49	61803231	VIS	4	
50	61815227	RONDELLE	4	

10	11



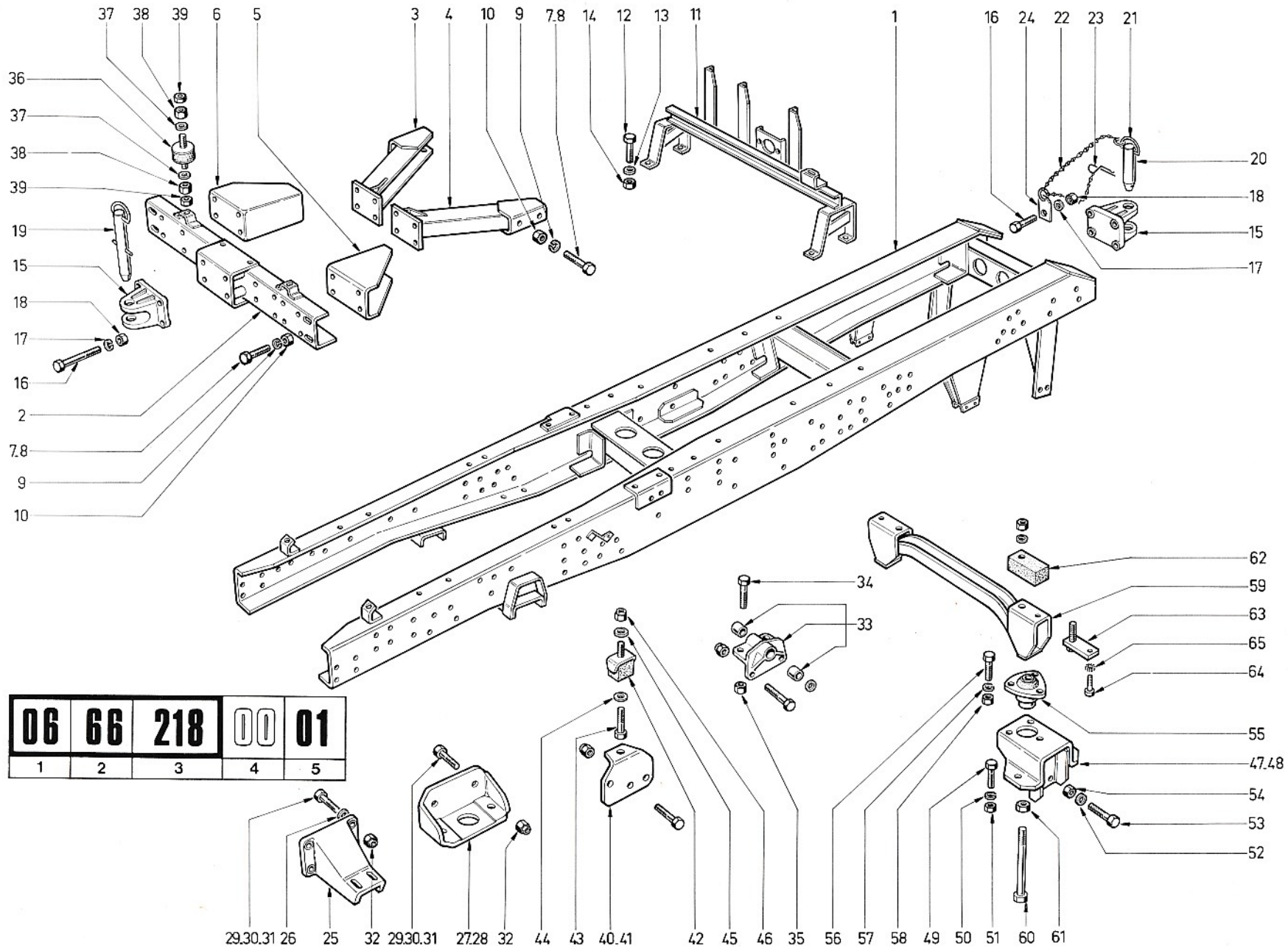

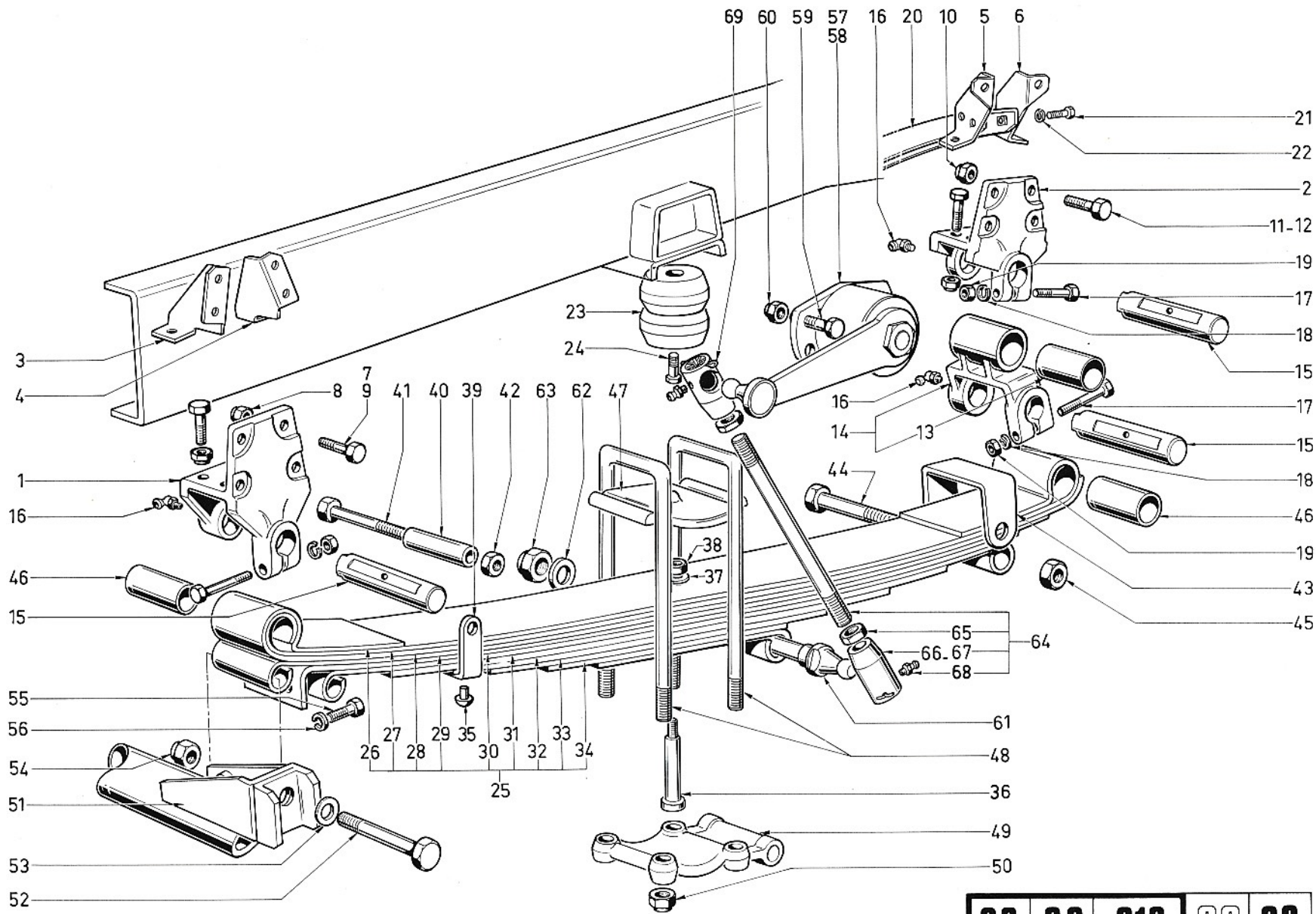

<b>06</b>	<b>66</b>	<b>218</b>	<b>00</b>	<b>02</b>
1	2	3	4	5

6	7	8	9	10
1	61577394	SUPPORT AV	2	
2	61230761	SUPPORT AR	2	
3	61230771	GOUSSET	2	
4	61230772	GOUSSET	2	
5	61230776	GOUSSET	2	
6	61230777	GOUSSET	2	
7	61803233	VIS LCN 50	8	
8	61801356	ECROU	16	
9	61803232	VIS LON 45	8	
10	61801356	ECROU	16	
11	61803232	VIS LCN 45	12	
12	61803233	VIS LON 50	4	
13	61211834	BAGLE	4	
14	61668819	JLMELLE ASS	2	
15	61211835	AXE	6	
16	61410502	GRAISSEUR	6	
17	61802696	VIS	6	
18	61815226	RONDELLE	6	
19	61801013	ECROU	6	
20	61662267	TRAVERSE	1	
21	61803196	VIS	8	
22	61815247	RONDELLE	8	
23	61676666	BUTEE	2	
24	61803184	VIS	2	
25	61670241	RESSORT ASS	2	

10	11

6	7	8	9	10
26	61575514	LAME N 1	2	
27	61575515	LAME N 2	2	
28	61575508	LAME N 3	2	
29	61575509	LAME N 4	2	
30	61575516	LAME N 5	2	
31	61575510	LAME N 6	2	
32	61575517	LAME N 7	2	
33	61575511	LAME N 8	2	
34	61575512	LAME N 9	2	
35	61408373	RIVET	4	
36	61676766	ETOQUIAU	2	
37	61115886	RONDELLE	2	
38	61425033	ECRGU	2	
39	61211827	BRIDE	4	
40	61211829	ENTRETOISE	4	
41	61575543	AXE	4	
42	61575544	ECROU	4	
43	61239294	BRIDE	4	
44	61803285	AXE	4	
45	61801015	ECROU	4	
46	61117593	BAGUE	4	
47	61239840	CALE	2	
48	61231242	ETRIER	4	
49	61575647	CHAPEAU	2	
50	61520111	ECROU	8	

10	11

<b>06</b>	<b>66</b>	<b>218</b>	<b>00</b>	<b>02</b>
1	2	3	4	5

DÉSIGNATION PLANCHE : SE RÉFÉRER AUX PAGES "SOMMAIRE"

PLATE DESIGNATION : REFER TO FLYLEAF

BILDBESCHRIFTUNG : SIEHE VORSATZBLÄTTER



6	7	8	9	10
51	61665369	TRAVERSE	1	
52	61803827	VIS	2	
53	61231389	RONDELLE		68
54	61520111	ECROU	2	
55	61803190	VIS	4	
56	61815247	RONDELLE	4	
57	61663346	AMORTISSEUR G	1	
58	61663347	AMORTISSEUR D	1	
59	61803191	VIS	8	
60	61801355	ECROU	8	
61	61231244	AXE	2	
62	61230412	RONDELLE	2	
63	61801358	ECROU	2	
64	61662648	BIELLE	2	
65	61704484	ECROU	4	
66	61701598	BOITE ROTULE	2	
67	61701599	BOITE ROTULE	2	
68	61410502	GRAISSEUR	4	
69	61819924	GOUPILLE	4	

6	7	8	9	10

10	11
68	Quantités : au choix Quantities : as desired Mengen : nach Wahl

10	11

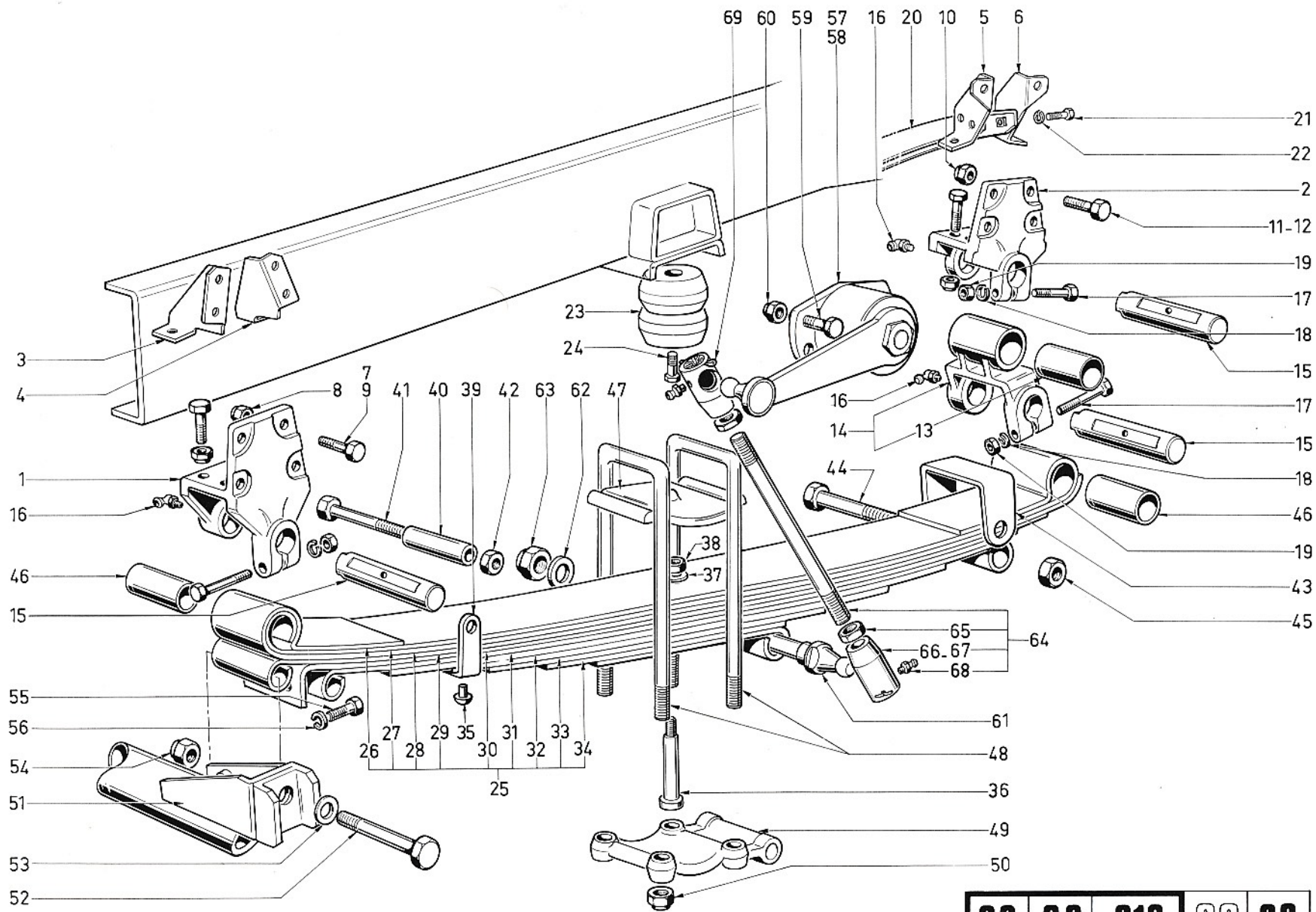

<b>06</b>	<b>66</b>	<b>218</b>	<b>00</b>	<b>02</b>
1	2	3	4	5

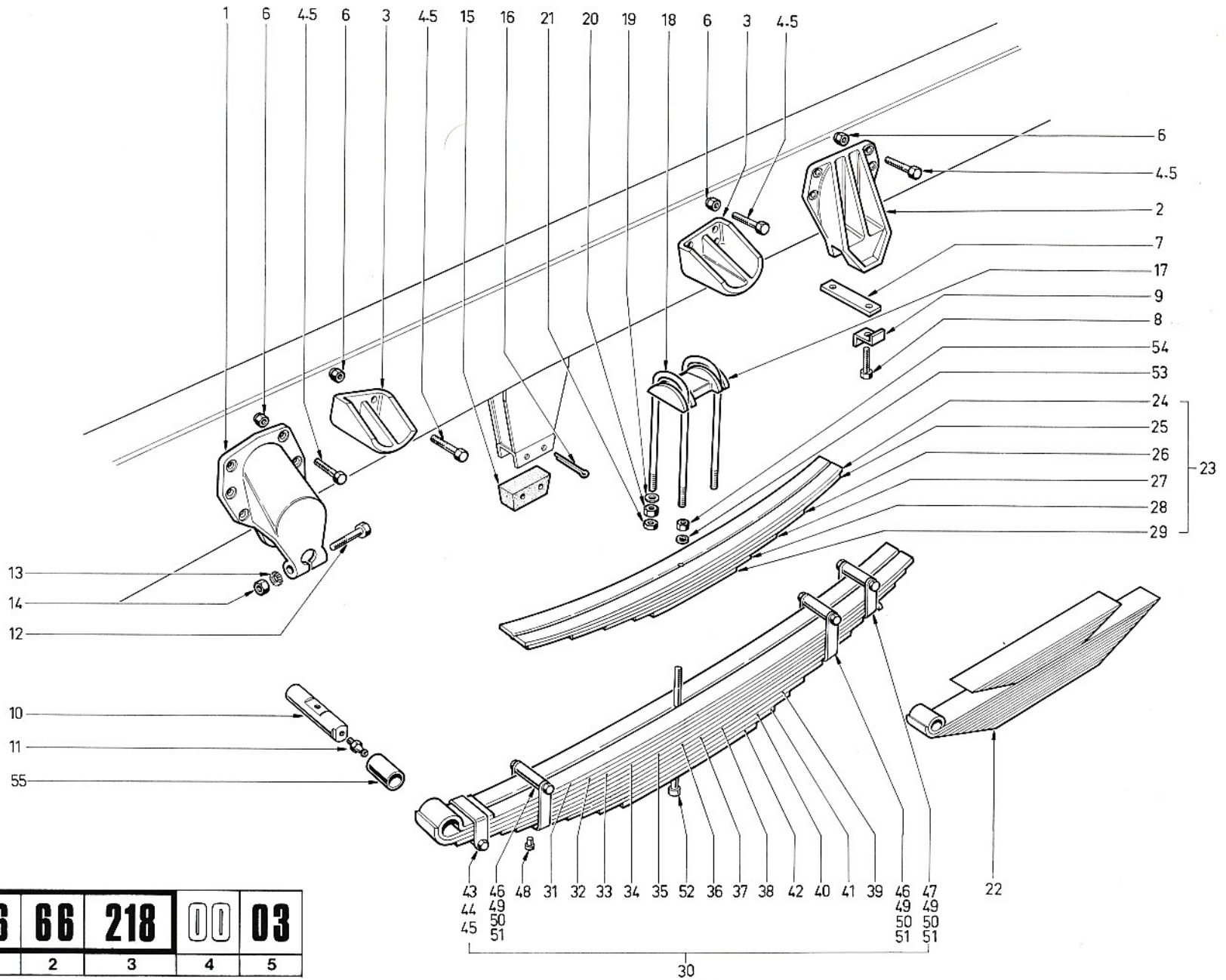

<b>06</b>	<b>66</b>	<b>218</b>	<b>00</b>	<b>03</b>
1	2	3	4	5

6	7	8	9	10
1	61224581	SUPPORT AV	2	
2	61224599	SUPPORT AR	2	
3	6122485C	BLTEE	4	
4	61803232	VIS LON 45	24	
5	61803231	VIS LON 40	18	
6	61801356	ECROU	42	
7	61129297	BRIDE	2	
8	6180273C	VIS	4	
9	61402011	FRE IN	4	
10	6121201C	AXE	2	
11	61410502	GRAISSEUR	2	
12	61802699	VIS	2	
13	61815226	RONDELLE	2	
14	61801013	ECROU	2	
15	61118063	BLTEE	2	
16	61819954	GOUPILLE	4	
17	61574582	SUPPORT	2	
18	61574588	ETRIER	4	
19	61400887	RONDELLE	8	
20	6140009C	ECROU	8	
21	61400092	ECROU	8	
22	61276756	RESSORT COMPLE	2	
23	61276762	RESSORT AUX	2	
24	61211979	LAME N 1	2	
25	6121198C	LAME N 2	2	

10	11

6	7	8	9	10
26	61211981	LAME N 3	2	
27	61211982	LAME N 4	2	
28	61211983	LAME N 5	2	
29	61211984	LAME N 6	2	
30	61276761	RESSORT PRINCI	2	
31	61211985	LAME N 1	2	
32	61211986	LAME N 2	2	
33	61211987	LAME N 3	2	
34	61211988	LAME N 4	2	
35	61211989	LAME N 5	2	
36	61211990	LAME N 6	2	
37	61211991	LAME N 7	2	
38	61211992	LAME N 8	2	
39	61211993	LAME N 9	2	
40	61211994	LAME N 10	2	
41	61211995	LAME N 11	2	
42	61211996	LAME N 12	2	
43	61212008	ETRIER	2	
44	61212002	VIS	2	
45	61425010	ECROU	2	
46	61211998	ETRIER	4	
47	61211997	ETRIER	2	
48	61408373	RIVET	6	
49	61211829	ENTRETOISE	6	
50	61575543	VIS	6	

10	11

**06 66 218 00 03**

1 2 3 4 5



DÉSIGNATION PLANCHE : SE RÉFÉRER AUX PAGES "SOMMAIRE"

PLATE DESIGNATION : REFER TO FLYLEAF

BILDBESCHRIFTUNG : SIEHE VORSATZBLÄTTER



6	7	8	9	10
51	61575544	ECROU	6	
52	61212005	ETOQUIAU	2	
53	61116668	RCNDELLE	2	
54	61425035	ECROU	2	
55	61212009	BAGLE	2	

10	11

6	7	8	9	10

10	11

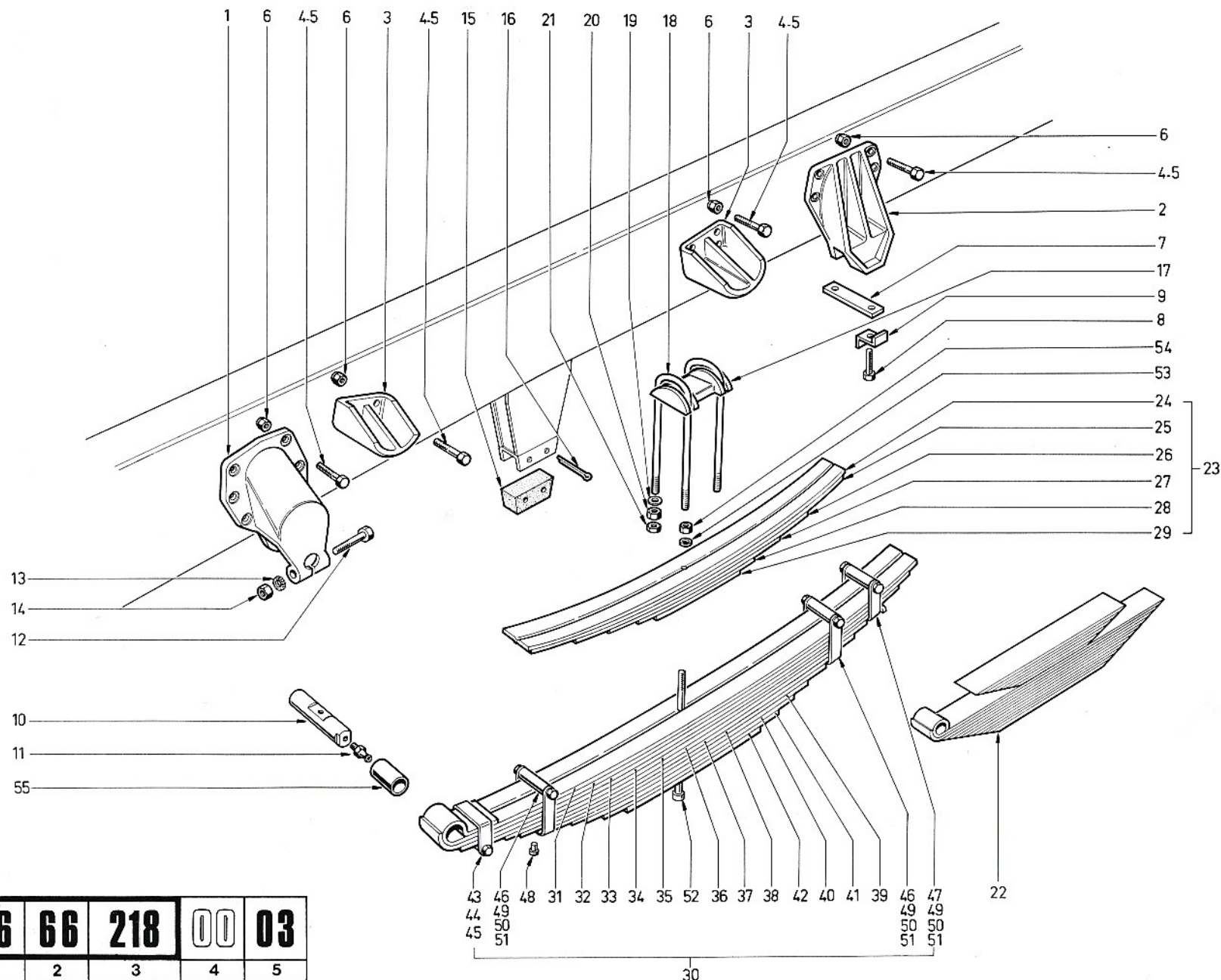

<b>06</b>	<b>66</b>	<b>218</b>	<b>00</b>	<b>03</b>
1	2	3	4	5