

06	ORG. BASE CADRES · SUSPENSIONS
	FRAMES · SUSPENSIONS BASIC COMPONENT
	GRUNDORGAN RAHMEN · RADAUFHANG.

66	ORGANE CADRES · SUSPENSIONS
	FRAMES · SUSPENSIONS COMPONENT
	ORGAN RAHMEN · RADAUFHANGUNGEN

210	C. A "GROUPE" TRACT. MOTEURS EN LIGNE
	"GROUPE" CAB TRACTOR IN LINE ENGINES
	"GROUPE" SATTELSCHLEPPER REIHENMOTOR.

VALIDITE DU
TYPE D'ORGANE

COMPONENT
APPLICABILITY

GÜLTIGKEIT
DES
ORGANTYPES

TYPE DE CHASSIS CHASSIS TYPE FAHRGESTELL TYP	N° DE CHASSIS CHASSIS Nr. FAHRGESTELL Nr.
T 10 A 200 T 10 A 200 R	320.526
T 11 A 200 T 11 A 200 R	315.882
T 220 A	231.060

1	ORGANE DE BASE	BASIC COMPONENT	GRUND-ORGAN
2	ORGANE	COMPONENT	ORGAN
3	TYPE D'ORGANE	COMPONENT TYPE	ORGANTYP
4	N° EDITION	CATAL. EDITION NUMBER	NUMMER DER AUSGABE
5	N° PLANCHE	PLATE NUMBER	BILD Nr.
6	REPERE	MARKING	KENNZIFFER

06	66	210	N° EDITION CATALOGUE	N° DE PLANCHE
1	2	3	4	5

Cadre de châssis <i>Frame</i> <i>Rahmen</i>	00	01
Suspension avant <i>Front suspension</i> <i>Vorderradaufhängung</i>	00	02
Suspension arrière <i>Rear suspension</i> <i>Hinterradaufhängung</i>	00	03
Barre stabilisatrice <i>Stabilisation bar</i> <i>Torsionstab</i>	00	04
Suspension moteur (L 63 S) <i>Power plant supports (engine L 63 S)</i> <i>Triebwerklager (Motor L 63 S)</i>	00	05

7	N° PIECE	PART N°	TEIL Nr.
8	DESIGNATION	DESIGNATION	BESCHRIFTUNG
9	QUANTITE	QUANTITY	MENGE
10	CODE OBSERVATIONS	CODE OF OBSERV.	ANMERKUNGEN KODE
11	DETAILS OBSERVATIONS	DETAILS OF OBSERV.	ANMERKUNGEN BEDEUT.

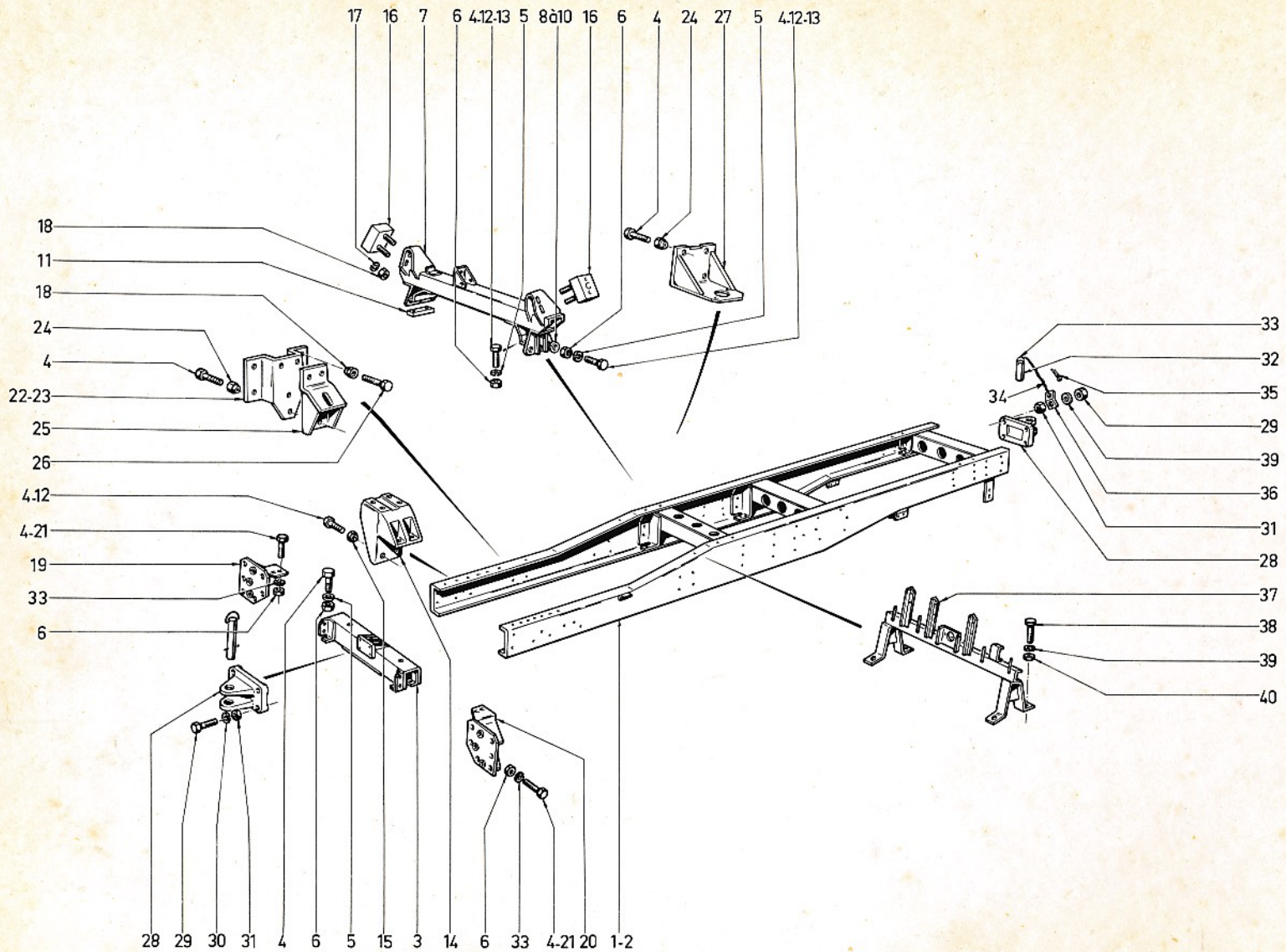

06	66	210	00	01
1	2	3	4	5

6	7	8	9	10
1	61665909	CHASSIS 3M40	1	
2	61665910	CHASSIS 4M00	1	
3	61667420	TRAVERSE AV	1	
4	61803190	VIS	36	
5	61815226	RONDELLE	33	
6	61801013	ECCROU	29	
7	61672175	SUPPORT CABINE	1	
8	61238487	RONDELLE		68
9	61238494	RONDELLE		68
10	61238495	RONDELLE		68
11	61576163	PLAQUE	2	
12	61803192	VIS	2	
13	61803191	VIS	1	
14	61237838	SUPPORT AV D	1	
15	61801355	ECROU	4	
16	61235439	SUPPORT ELASTI	2	
17	61815040	RONDELLE	4	
18	61801354	ECROU	12	
19	61235463	SUPPORT D	1	
20	61235464	SUPPORT G	1	
21	61803189	VIS	12	
22	61237171	SUPPORT AV G	1	
23	61237170	SUPPORT AV D	1	
24	61801355	ECROU	14	
25	61237172	SUPPORT	2	

10	11
68	Quantités : au choix Quantities : as desired Mengen : nach Wahl

6	7	8	9	10
26	61803149	VIS		8
27	61232538	SUPPORT AR		2
28	61217007	CHAPE		2
29	61803273	VIS		8
30	61815249	RONDELLE		8
31	61801015	ECROU		8
32	61127168	AXE		1
33	61127449	ANNEAU		1
34	61128100	CHAINE		1
35	61127450	GOUPILLE		1
36	61128056	PLAQUETTE		1
37	61670008	SUPPORT ASS		1
38	61802647	VIS		4
39	61815306	RONDELLE		4
40	61801012	ECROU		4

10	11

06 66 210 00 02

SE RÉFÉRER AUX PAGES "SOMMAIRE"

PLATE DESIGNATION : REFER TO FLYLEAF

BILDBESCHRIFTUNG : SIEHE VORSATZBLÄTTER



6	7	8	9	10
1	61239278	MAIN AV G 9LAM	1	
2	61239279	MAIN AV G 10LA	1	
3	61239276	MAIN AV D 9LAM	3	
4	61239277	MAIN AV D 10LA	3	
5	61234546	CALE	2	
6	61803272	VIS	16	
7	61803273	VIS	4	
8	61801357	ECROU	21	
9	61668635	JUMELLE ASS 9L	2	
10	61231505	BAGUE	2	
11	61668636	JUMELLE AS 10L	2	
12	61235751	BAGUE	2	
13	61220446	AXE RESS 9LAME	6	
14	61212719	AXE RESS 10LAM	5	
15	61802696	VIS	6	
16	61815226	RONDELLE	6	
17	61801013	ECROU	6	
18	61836015	GRAISSEUR	1	
19	61836035	GRAISSEUR	5	
20	61217184	SUPPORT G 9LAM	1	
21	61217186	SUPPORT D 9LAM	1	
22	61217133	SUPPORT G 10LA	1	
23	61217185	SUPPORT D 10LA	1	
24	61239869	BUTEE	2	
25	61116500	ETRIER 9LAME	4	

10	11

6	7	8	9	10
26	61216788	ETRIER 10LAM	4	
27	61815010	RONDELLE 9LAME	10	
28	61400070	ECROU 9LAME	8	
29	61400072	ECROU 9LAME	8	
30	61815009	RONDELLE	8	
31	61095033	ECROU 10LAME	8	
32	61668634	RESSORT ASS 9L	2	
33	61573697	LAME 1	2	
34	61239271	LAME 2	2	
35	61239272	LAME 3	2	
36	61239273	LAME 4	2	
37	61573698	LAME 5	2	
38	61573699	LAME 6	2	
39	61573700	LAME 7	2	
40	61573701	LAME 8	2	
41	61573702	LAME 9	2	
42	61212754	ETOQUIAJ	2	
43	61115885	RONDELLE	2	
44	61115886	RONDELLE	2	
45	61425033	ECROU	2	
46	61223911	BRIDE	4	
47	61211827	BRIDE	4	
48	61408373	RIVET	4	
49	61211829	ENTRETOISE	4	
50	61575543	AXE	4	

10	11

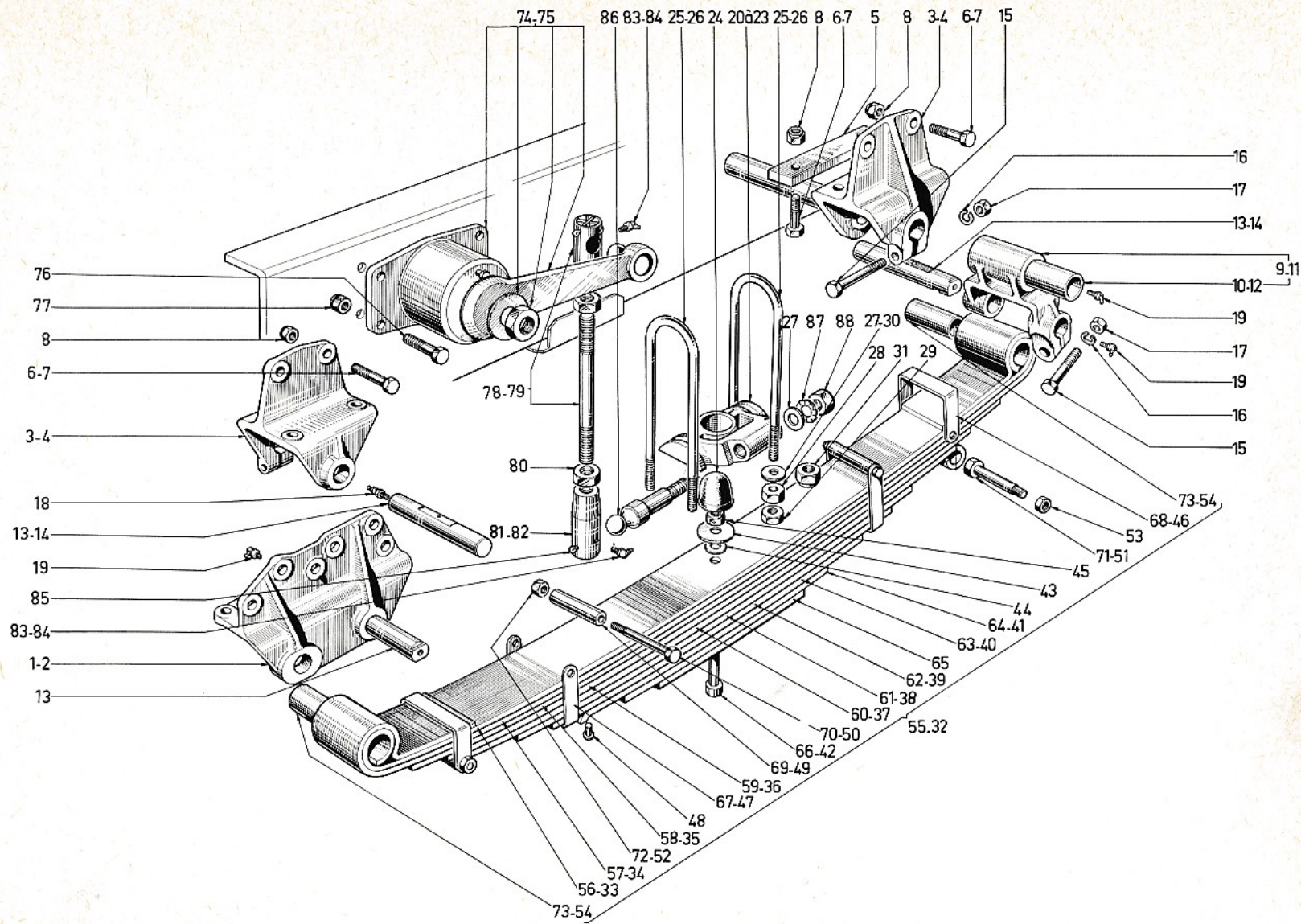

06	66	210	00	02
1	2	3	4	5

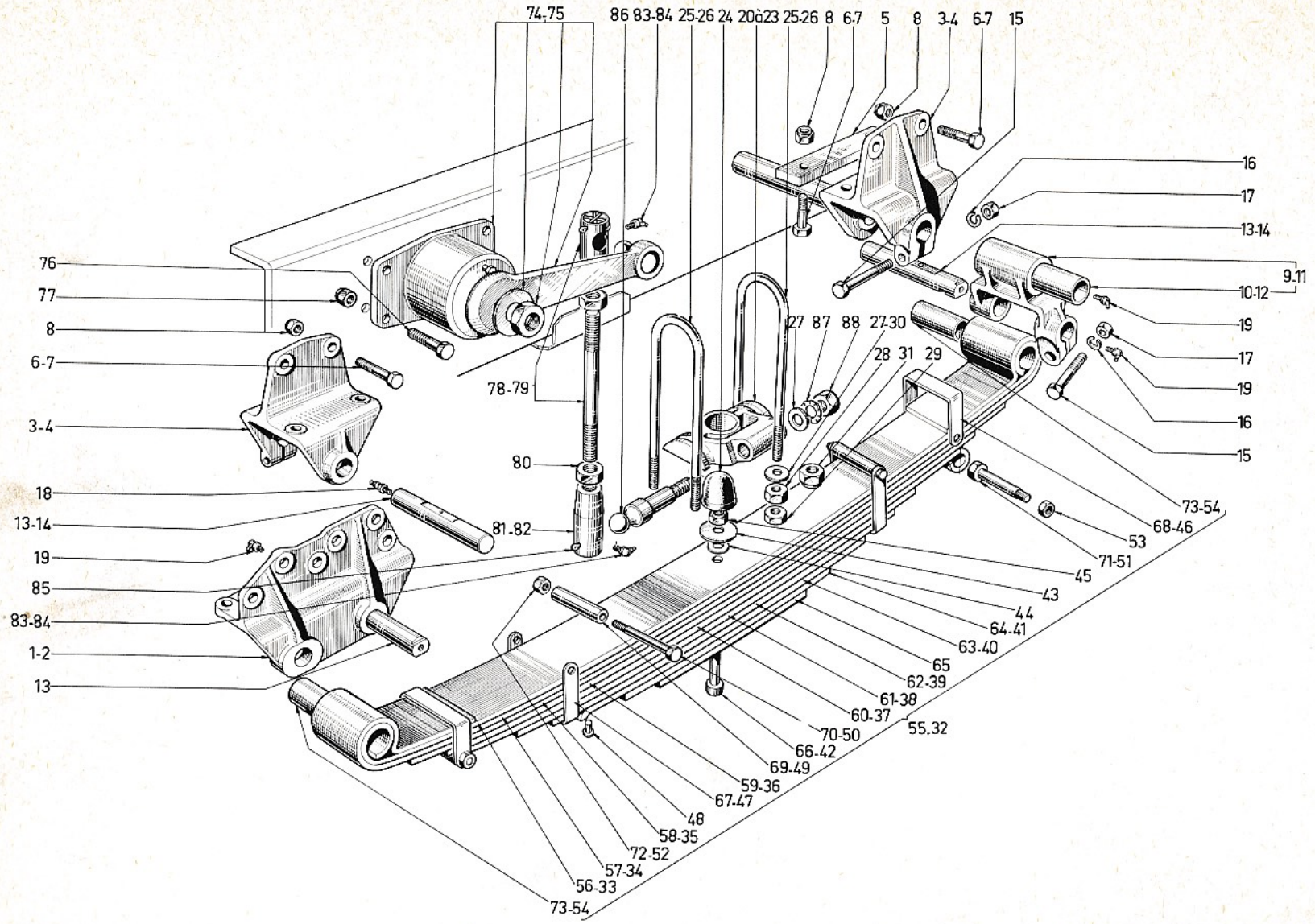

06	66	210	00	02
1	2	3	4	5

6	7	8	9	10
51	61803285	AXE	4	
52	61575544	ECROU	4	
53	61801015	ECROU	4	
54	61231355	BAGUE	4	
55	61668629	RESSORT AS 10L	2	
56	61573703	LAME 1	2	
57	61239255	LAME 2	2	
58	61239256	LAME 3	2	
59	61239257	LAME 4	2	
60	61573704	LAME 5	2	
61	61573705	LAME 6	2	
62	61573706	LAME 7	2	
63	61573707	LAME 8	2	
64	61573708	LAME 9	2	
65	61573709	LAME 10	2	
66	61231636	ETOUQUIAU	2	
67	61214603	BRIDE	4	
68	61227928	BRIDE	4	
69	61207251	ENTRETOISE	4	
70	61207252	AXE	4	
71	61803283	AXE	4	
72	61425007	ECROU	4	
73	61235752	BAGUE	4	
74	61663346	AMORTISSEUR G	1	
75	61663347	AMORTISSEUR D	1	

6	7	8	9	10
76	61803191	VIS	8	
77	61801355	ECROU	8	
78	61669063	BIELLE G ASS	1	
79	61669064	BIELLE D ASS	1	
80	61704484	ECROU	4	
81	61701598	BOITE ROTJLE G	2	
82	61701599	BOITE ROTJLE D	2	
83	61410514	GRAISSEUR	2	
84	61410502	GRAISSEUR	2	
85	61819933	GOUPILLE	4	
86	61573695	ROTULE	2	
87	61400964	RONDELLE	2	
88	61801070	ECROU	2	

10	11

10	11

06	66	210	00	03
1	2	3	4	5

DÉSIGNATION PLANCHE : SE RÉFÉRER AUX PAGES "SOMMAIRE"

PLATE DESIGNATION : REFER TO FLYLEAF

BILDBESCHRIFTUNG : SIEHE VORSATZBLÄTTER



6	7	8	9	10
1	61234718	MAIN	4	
2	61111878	BUTEE	4	
3	61803231	VIS	16	
4	61803232	VIS	24	
5	61801356	ECROU	40	
6	61670017	JUMELLE ASS	2	
7	61234756	BAGUE	2	
8	61212010	AXE	5	
9	61802699	VIS	6	
10	61815226	RONDELLE	6	
11	61801013	ECROU	6	
12	61836005	GRAISSEUR	6	
13	61574582	SUPPORT	2	
14	61118063	BUTEE CAOUTCHO	2	
15	61819954	GOUPILLE	4	
16	61668130	RESSORT ASS	2	
17	61668131	RESSORT PRINCI	2	
18	61238629	LAME 1	2	
19	61238630	LAME 2	2	
20	61238631	LAME 3	2	
21	61238632	LAME 4	2	
22	61238633	LAME 5	2	
23	61238634	LAME 6	2	
24	61238635	LAME 7	2	
25	61238636	LAME 8	2	

6	7	8	9	10
26	61238637	LAME 9	2	
27	61238638	LAME 10	2	
28	61238639	LAME 11	2	
29	61238640	LAME 12	2	
30	61238641	LAME 13	2	
31	61238642	LAME 14	2	
32	61211998	ETRIER	2	
33	61211829	ENTRETOISE	4	
34	61575543	AXE	4	
35	61575544	ECROU	4	
36	61408373	RIVET	4	
37	61668132	RESSORT	2	
38	61238643	LAME 1	2	
39	61238644	LAME 2	2	
40	61238645	LAME 3	2	
41	61238646	LAME 4	2	
42	61238647	LAME 5	2	
43	61238648	LAME 6	2	
44	61223910	ETRIER	2	
45	61235860	ETOQUIAU	2	
46	61116668	RONDELLE	2	
47	61801015	ECROU	2	
48	61229943	BAGUE	2	
49	61574585	ETRIER	4	
50	61400887	RONDELLE	8	834

10	11
834	Avec Barre stabilisatrice With torsion bar Mit Torsionsstab

10	11

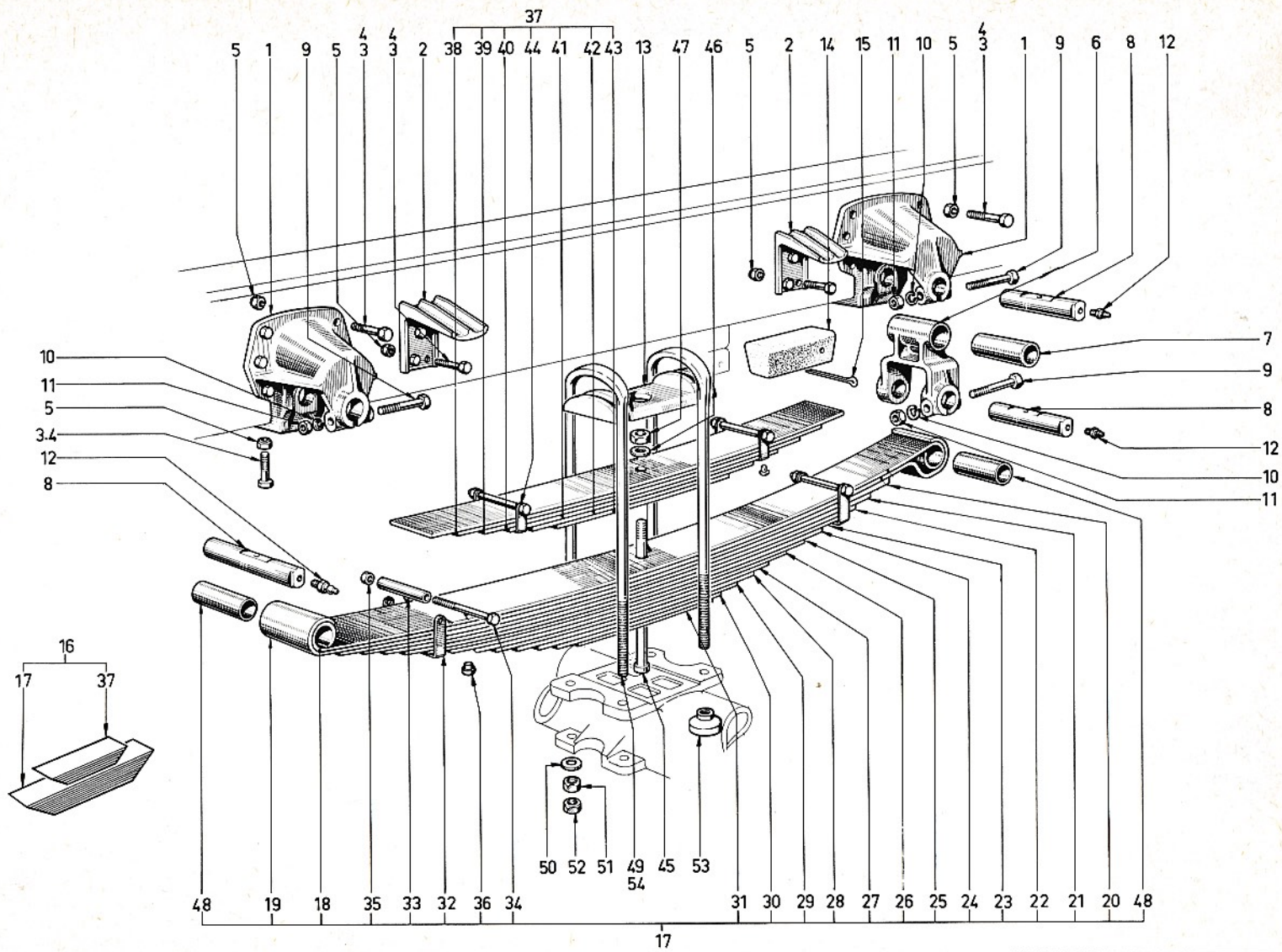

06	66	210	00	03
1	2	3	4	5

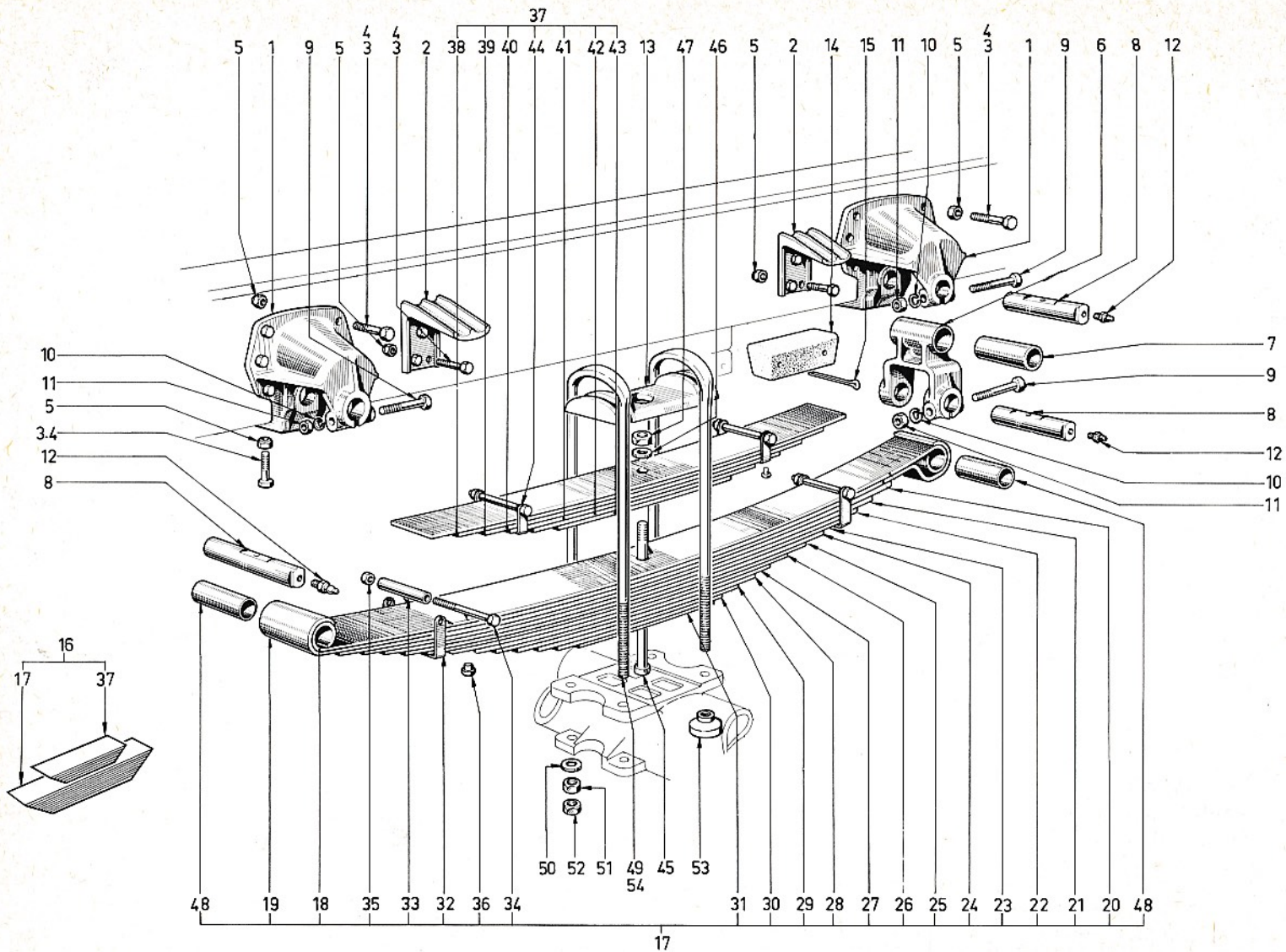

06	66	210	00	03
1	2	3	4	5



DÉSIGNATION PLANCHE : SE RÉFÉRER AUX PAGES "SOMMAIRE"
 PLATE DESIGNATION : REFER TO FLYLEAF
 BILDBESCHRIFTUNG : SIEHE VORSATZBLÄTTER

06	66	210	00	03
1	2	3	4	5

6	7	8	9	10
51	61400090	ECROU	8	
52	61400092	ECROU	6	
53	61573516	ADAPTATEUR	2	
54	61574586	ETRIER	4	

6	7	8	9	10

10	11

10	11

06 66 210 00 04

DÉSIGNATION PLANCHE : SE RÉFÉRER AUX PAGES "SOMMAIRE"

PLATE DESIGNATION : REFER TO FLYLEAF

BILDBESCHRIFTUNG : SIEHE VORSATZBLÄTTER



6	7	8	9	10
1	61215495	RENFORT	2	
2	61803273	VIS	4	
3	61815043	RONDELLE	4	
4	61815249	RONDELLE	4	
5	61801015	ECROU	4	
6	61229204	SUPPORT	2	
7	61663299	COLLIER	2	
8	61231900	SILENTBLOC	2	
9	61231901	PIVOT	2	
10	61400887	RONDELLE	4	
11	61231898	ECROU	4	
12	61235215	BARRE STABILIS	1	
13	61803199	VIS	4	
14	61815226	RONDELLE	12	
15	61801013	ECROU	12	
16	61229205	SUPPORT	2	
17	61803231	VIS	8	
18	61801356	ECROU	8	
19	61803274	VIS	4	
20	61801357	ECROU	4	
21	61664760	BRAS ASS	2	
22	61231896	SILENTBLOC	2	
23	61231895	CHAPEAU	2	
24	61231897	PIVOT	2	
25	61232030	BAGUE	2	

6	7	8	9	10
26	61803201	VIS	8	

10	11

10	11

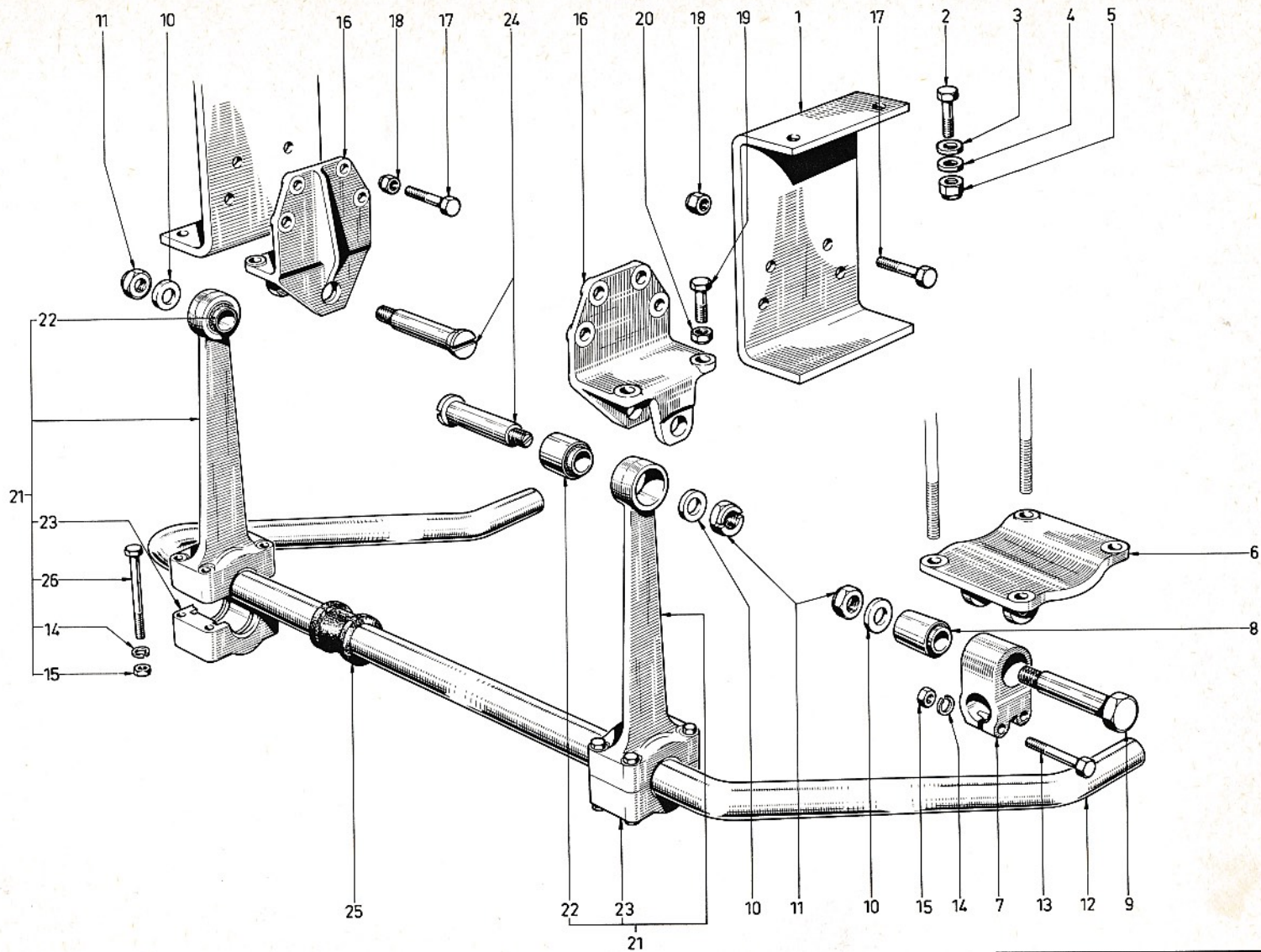

06	66	210	00	04
1	2	3	4	5

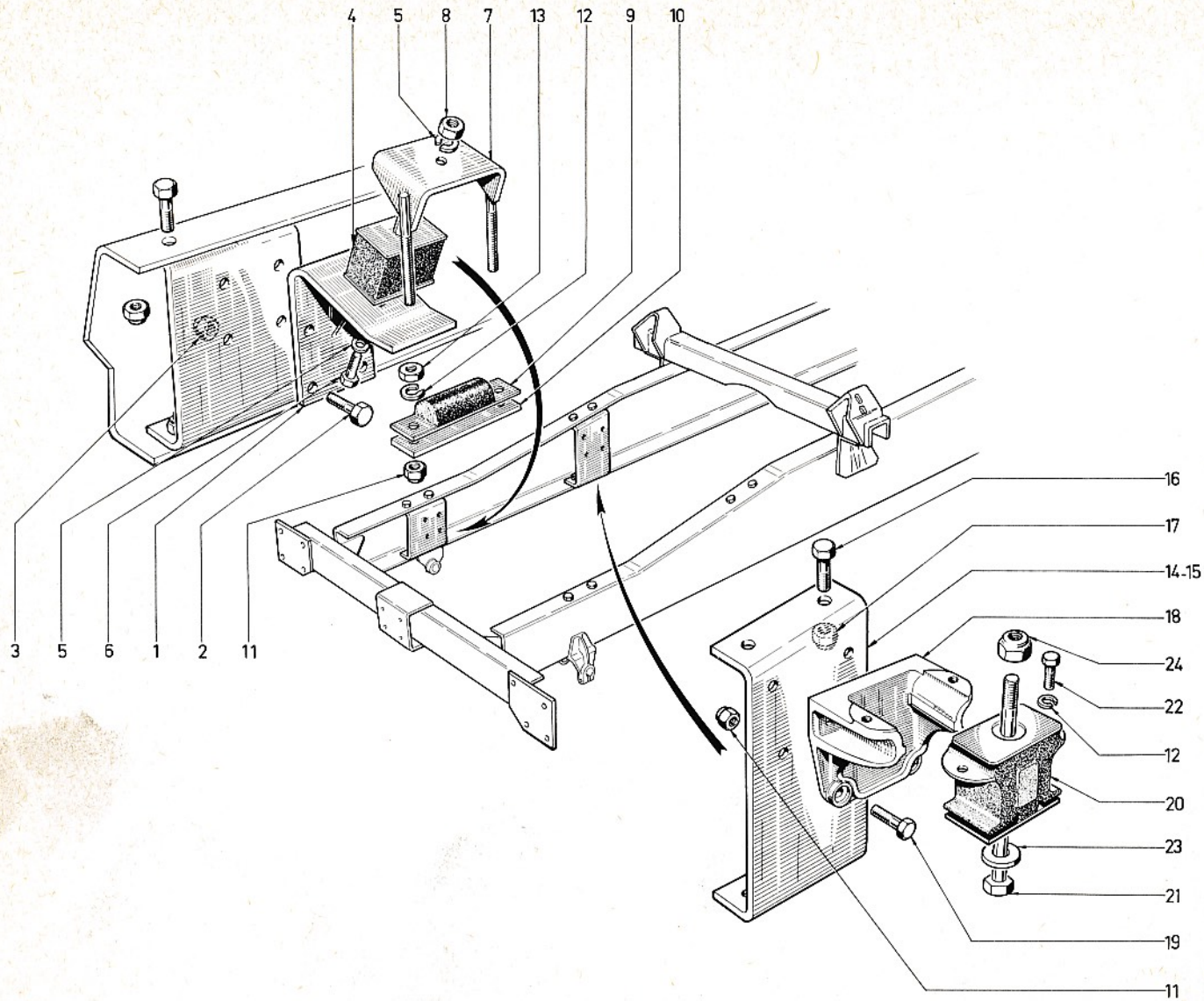

06	66	210	00	05
1	2	3	4	5

6	7	8	9	10
1	61227527	SUPPORT	1	
2	61803187	VIS	4	
3	61815226	RONDELLE	4	
4	61237171	SUPPORT AV G	1	
5	61237170	SUPPORT AV D	1	
6	61803190	VIS	14	
7	61801355	ECROU	14	
8	61237172	SUPPORT AV	2	
9	61803149	VIS	12	
10	61801354	ECROU	16	
11	61235241	ELEMENT ELASTI	2	
12	61815225	RONDELLE	4	
13	61815054	RONDELLE	2	
14	61225310	ECROU	4	
15	61232538	SUPPORT AR	2	
16	61235172	ELEMENT AR	2	
17	61225017	AXE	2	
18	61233150	RONDELLE	2	
19	61230305	RONDELLE	2	
20	61815007	RONDELLE		68
21	61520014	ECROU	2	
22	61819922	GOUPILLE	2	
23	61236462	LIMITEUR	2	
24	61231224	CALE		68
25	61803150	VIS	4	

6	7	8	9	10
26	61815005	RONDELLE	4	

10	11
68	Quantités : au choix <i>Quantities : as desired</i> <i>Mengen : nach Wahl</i>

10	11