

06 **ORG. BASE CADRES-SUSPENS.**
 FRAMES-SUSPENSIONS BASIC COMPONENT
 GRUNDORGAN RAHMEN-RADAUFHÄNGUNG

66 **ORG. CADRES-SUSPENSIONS**
 FRAMES-SUSPENSIONS COMPONENT
 ORGAN RAHMEN-RADAUFHÄNGUNG

207 **"BIG-JOB" PORTEURS V8**
"BIG-JOB" "CARRIER" ENGINE V8
"BIG-JOB" LASTER MOTOR V8

06	66	207	N° EDITION CATALOGUE	N° DE PLANCHE
1	2	3	4	5

Cadre de châssis	00	01
<i>Frame</i>		
<i>Rahmen</i>		
Suspension avant	00	02
<i>Front suspension</i>		
<i>Vorderradaufhängung</i>		
Suspension arrière	00	03
<i>Rear suspension</i>		
<i>Hinterradaufhängung</i>		

P 270

CATALOGUE RELEVÉ AU : 17 - 5 - 72
 CSA châssis N° 342-004
 "BIG-JOB"

CATALOG ACCOUNTING AS OF 17-5-72
 "BIG-JOB" chassis N° 342-004
 cab

KATALOG AUSZUG ZUM 17 - 5 - 72
 "BIG-JOB" chassis Nr. 342-004
 kurzhauber

1	ORGANE DE BASE	BASIC COMPONENT	GRUND-ORGAN
2	ORGANE	COMPONENT	ORGAN
3	TYPE D'ORGANE	COMPONENT TYPE	ORGANTYP
4	N° ÉDITION	CATAL. EDITION NUMBER	NUMMER DER AUSGABE
5	N° PLANCHE	PLATE NUMBER	BILD Nr.
6	REPÈRE	MARKING	KENNZIFFER

7	N° PIÈCE	PART N°	TEIL Nr.
8	DÉSIGNATION	DESIGNATION	BESCHRIFTUNG
9	QUANTITÉ	QUANTITY	MENGE
10	CODE OBSERVATIONS	CODE OF OBSERV.	ANMERKUNGEN KODE
11	DÉTAILS OBSERVATIONS	DETAILS OF OBSERV.	ANMERKUNGEN BEDEÜT.



Référence : 655.635
 Kennzahl: 655.635
 Edition: 15-7-72
 Ausgabe:

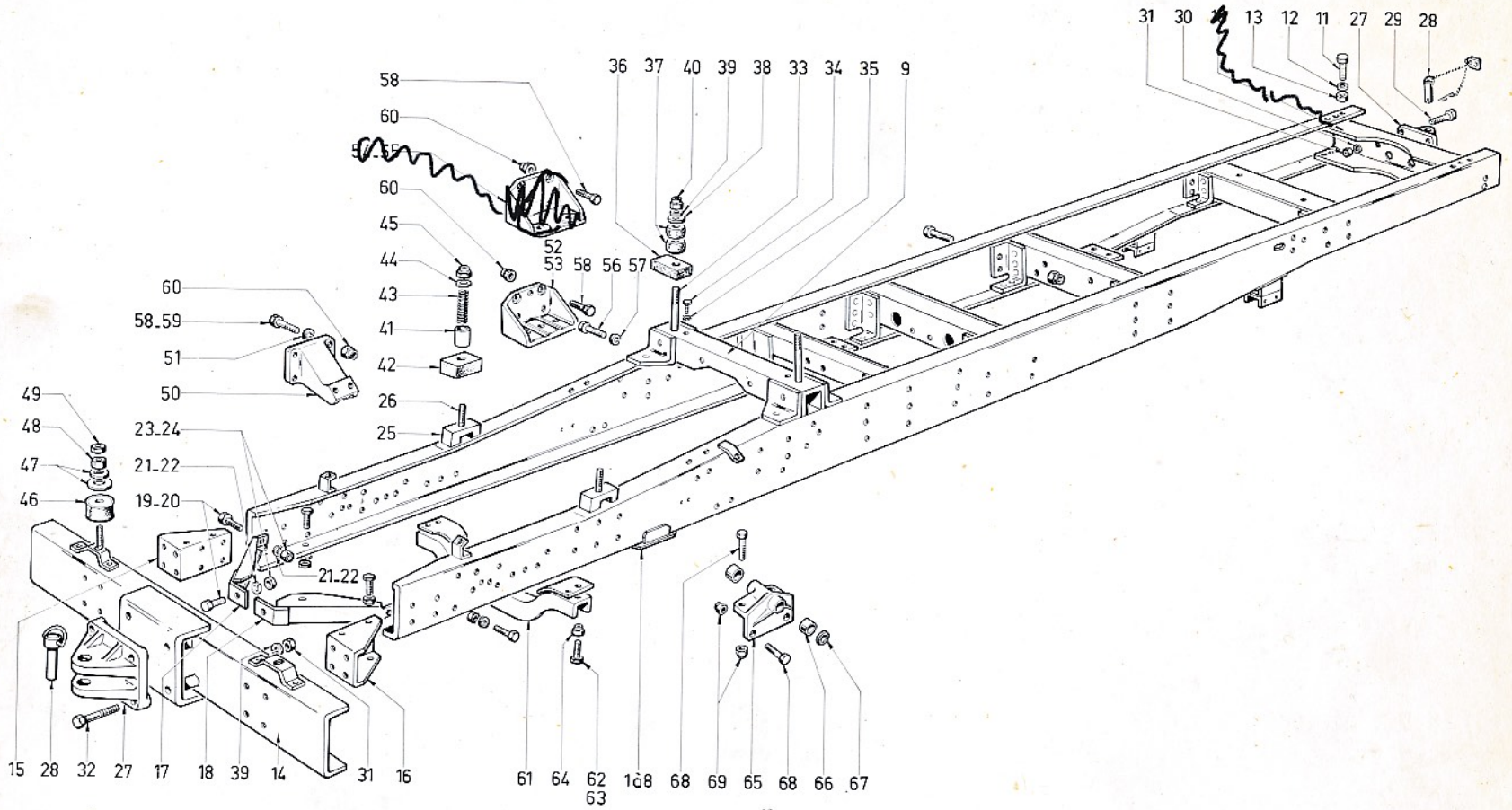

06	66	207	00	01
1	2	3	4	5

6	7	8	9	10
1	61657973	CADRE EMP 4000 *	1	340
2	61657974	CADRE EMP 4600	1	340
3	61657975	CADRE EMP 5180	1	340
4	61657976	CADRE EMP 5750	1	340
5	61666068	CADRE EMP 4000 **	1	782
6	61666069	CADRE EMP 4600	1	782
7	61666070	CADRE EMP 5180	1	782
8	61666071	CADRE EMP 5750	1	782
9	61298434	TRAVERSE ASS	1	782
10	61236074	TRAVERSE AR AS	1	778
11	61803230	VIS	12	
12	61815227	RONDELLE	12	
13	61801014	ECROU	12	
14	61293463	TRAVERSE AVANT	1	
15	61216666	GOUSSET DROIT	2	
16	61216667	GOUSSET GAUCHE	2	
17	61293447	TIRANT DROIT	1	
18	61293446	TIRANT GAUCHE	1	
19	61803189	VIS	24	
20	61803283	VIS	4	
21	61815247	RONDELLE	24	
22	61815249	RONDELLE	4	
23	61801013	ECROU	24	
24	61801015	ECROU	4	
25	61132354	SUPPORT	2	

6	7	8	9	10
26	61803206	VIS	2	
27	61217007	CHAPE	2	
28	61127168	AXE 69'953 mit Stossdampf CHANTIER	2	
29	61803272	VIS	4	
30	61815249	RONDELLE	4	
31	61801015	ECROU	4	
32	61803283	VIS	4	
33	61657961	VIS	2	
34	61803917	VIS	2	
35	61815303	RONDELLE	2	
36	61203545	CALE	2	
37	61117743	CALE	4	
38	61220361	RONDELLE	2	
39	61077378	RONDELLE	2	
40	61801355	ECROU	2	
41	61132895	ENTRETOISE	2	
42	61240588	BLOC	2	
43	61132894	RESSORT	2	
44	61238476	RONDELLE	2	
45	61801355	ECROU	2	
46	61234244	PLOT	2	
47	61815040	RONDELLE	4	
48	61801012	ECROU	4	
49	61801705	ECROU	4	
50	61220084	SUPPORT	2	

10	11
0340	Châssis - P 270 - «Chantiers» Chassis - P 270 - "Chantiers" ← P 270 271'782 * Chassis - P 270 - «Chantiers»
0778	Châssis 4m600 - 5m180 - 5m750 Chassis 4m600 - 5m180 - 5m750 Fahrgestell 4m600 5m180 - 5m750
0782	Châssis P340 - P 270 Chassis P340 ← 271'605 Fahrgestell P340 271'658 **

10	11

06	66	207	00	01
1	2	3	4	5



DÉSIGNATION PLANCHE : SE RÉFÉRER AUX PAGES "SOMMAIRE"

PLATE DESIGNATION : REFER TO FLYLEAF

BILDBESCHRIFTUNG : SIEHE VORSATZBLÄTTER



6	7	8	9	10
51	61226140	ENTRETOISE	8	
52	61232639	SUPPORT GAUCHE	1	
53	61232638	SUPPORT DROIT	1	
54	61238368	SUPPORT GAUCHE	1	782
55	61238369	SUPPORT DROIT	1	782
56	61803189	VIS	6	
57	61815226	RONDELLE	6	
58	61803192	VIS	10	
59	61803193	VIS	2	
60	61801355	ECROU	12	
61	61293817	TRAVERSE	1	
62	61803270	VIS	2	
63	61803271	VIS	2	
64	61801431	ECROU	4	
65	61666378	SUPPORT ASS	1	
66	61236151	BAGUE	2	
67	61224667	JOINT	1	
68	61803191	VIS	4	
69	61801355	ECROU	4	

6	7	8	9	10

10	11
0782	Chassis P340 Chassis P340 Fahrgestell P340

10	11

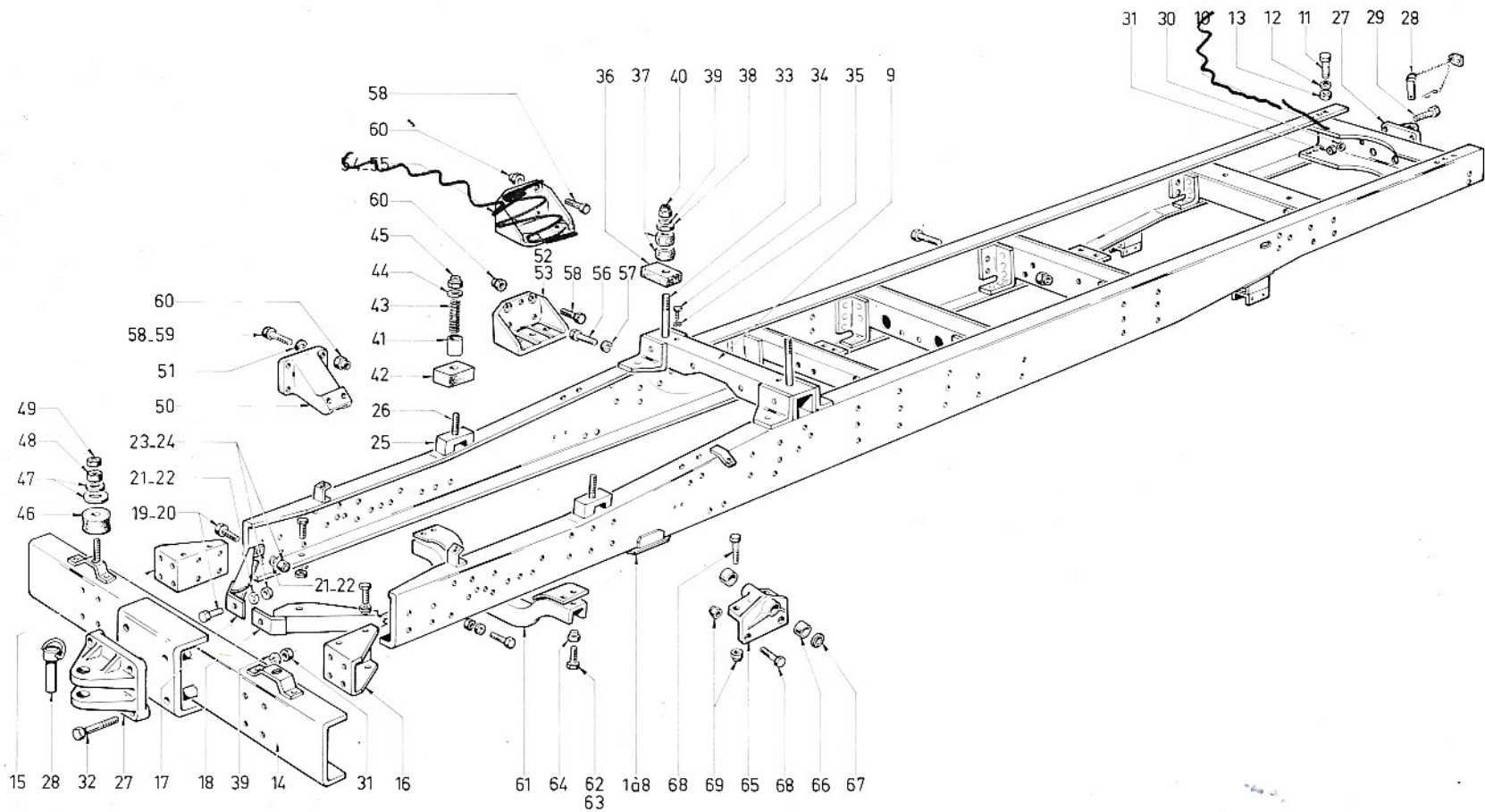

06	66	207	00	01
1	2	3	4	5

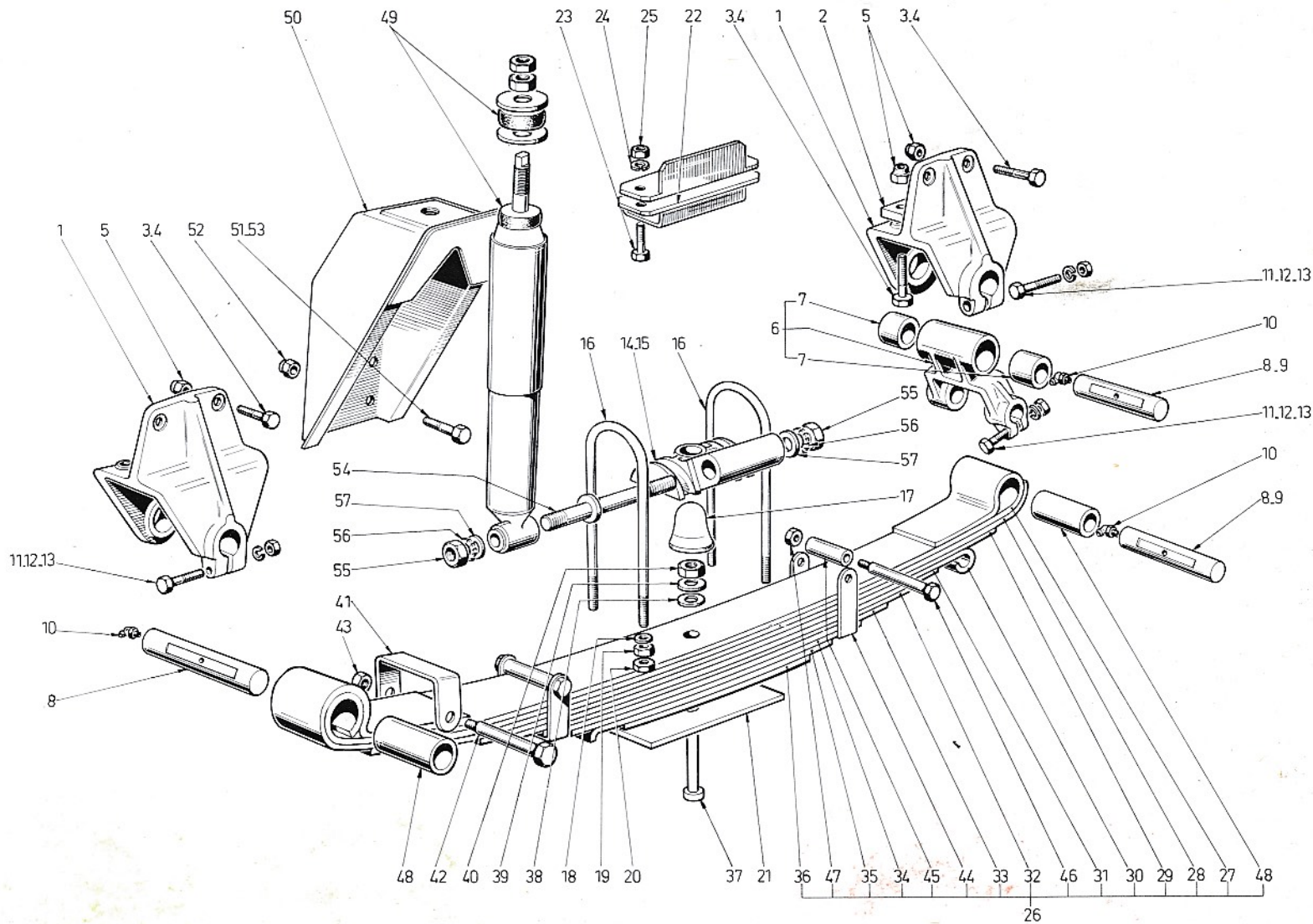

06	66	207	00	02
1	2	3	4	5

6	7	8	9	10
1	61239276	MAIN	4	
2	61230296	CALE	2	
3	61803272	VIS	12	
4	61803275	VIS	4	
5	61801357	ECROU	16	
6	61276577	JUMELLE ASS	2	
7	61211834	BAGUE	4	
8	61211835	AXE	4	
9	61220446	AXE AR GAUCHE	2	
10	61410502	GRAISSEUR	6	
11	61802696	VIS	6	
12	61815226	RONDELLE	6	
13	61801013	ECROU	6	
14	61217184	SUPPORT GAUCHE	1	
15	61217186	SUPPORT DROIT	1	
16	61116500	ETRIER	4	
17	61218276	BUTEE	2	
18	61815010	RONDELLE	8	
19	61400070	ECROU	8	
20	61400072	ECROU	8	
21	61211832	CALE	2	
22	61234187	BUTEF	2	
23	61802690	VIS	4	
24	61815247	RONDELLE	4	
25	61801013	ECROU	4	

6	7	8	9	10
26	61668644	RESSORT AVANT	2	
27	61578319	LAME 1	2	
28	61239295	LAME 2	2	
29	61239296	LAME 3	2	
30	61239297	LAME 4	2	
31	61211821	LAME 5	2	
32	61211822	LAME 6	2	
33	61211823	LAME 7	2	
34	61573714	LAME 8	2	
35	61211825	LAME 9	2	
36	61573715	LAME 10	2	
37	61211830	ETOQUIAU	2	
38	61115885	RONDELLE	2	
39	61115886	RONDELLE	2	
40	61425033	ECROU	2	
41	61239294	BRIDE	4	
42	61575543	AXE	4	
43	61575544	ECROU	4	
44	61211827	BRIDE	4	
45	61211829	ENTRETOISE	4	
46	61803285	AXE	4	
47	61801015	ECROU	4	
48	61117593	BAGUE	4	
49	61253779	AMORTISSEUR	2	
50	61293363	SUPPORT	2	

10	11
	<div style="border: 1px solid black; background-color: #f08080; padding: 10px; text-align: center;"> <p>Gilt nur für CH-No: 271'658</p> </div>

10	11
	<div style="border: 1px solid black; background-color: #90ee90; padding: 10px; text-align: center;"> <p>Für Ch-No. 271'605 271'782 im P 12 R2 - Katalog schauen!</p> </div>

06	66	207	00	02
1	2	3	4	5

DÉSIGNATION PLANCHE : SE RÉFÉRER AUX PAGES "SOMMAIRE"
 PLATE DESIGNATION : REFER TO FLYLEAF
 BILDBESCHRIFTUNG : SIEHE VORSATZBLÄTTER



6	7	8	9	10
51	61803192	VIS	6	
52	61801355	ECROU	8	
53	61803190	VIS	2	
54	61217121	AXE	2	
55	61801070	ECROU	4	
56	61400964	RONDELLE	4	
57	61815010	RONDELLE	4	

6	7	8	9	10

Application - Application - Anwendung

 A partir de Juillet 1975
 From July 1975
 Ab Juli 1975

06	66	207	00	02
-----------	-----------	------------	-----------	-----------

PLANCHE - PLATE - BLATT

N° modification Change N° Änderungsnr.	564
--	------------

Rep. Mark. Kennzr.	Ancien montage Previous fitting Alte Montage	Pièces supprimées Parts cancelled Entfallende Teile	Nouveau montage New fitting Neue Montage	Désignation Designation Bezeichnung	Quant. Quant. Menge	Code* Code* Code*	Observations Observations Bemerkungen
49	253 779		686 322	Amortisseur - Shock absorber - Stossdämpfer	2	1	
N.D.			581 697	Rondelle inférieure - Inferior washer - Scheibe unter	2		
N.D.			581 698	Rondelle supérieure - Superior washer - Scheibe ober	2		
N.D.			582 750	Coupelle épaulée - Cup - Manschette	4		
N.D.			582 749	Tampon élastique - Bump stop - Federputfer	4		
10 N.D.			142 139	Silent-bloc - Rubber joint - Gummipackung	2		

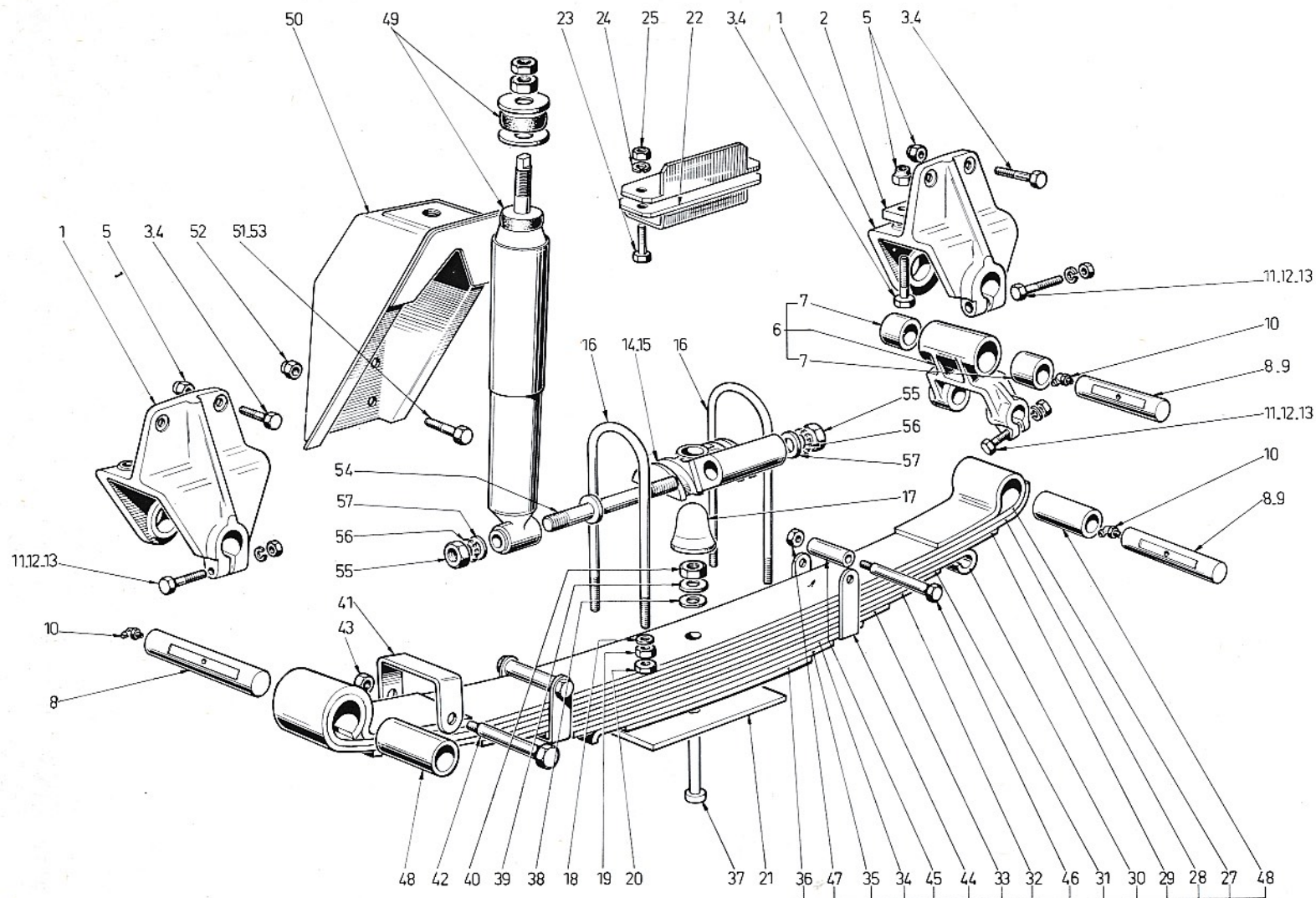

26

06	66	207	00	02
1	2	3	4	5

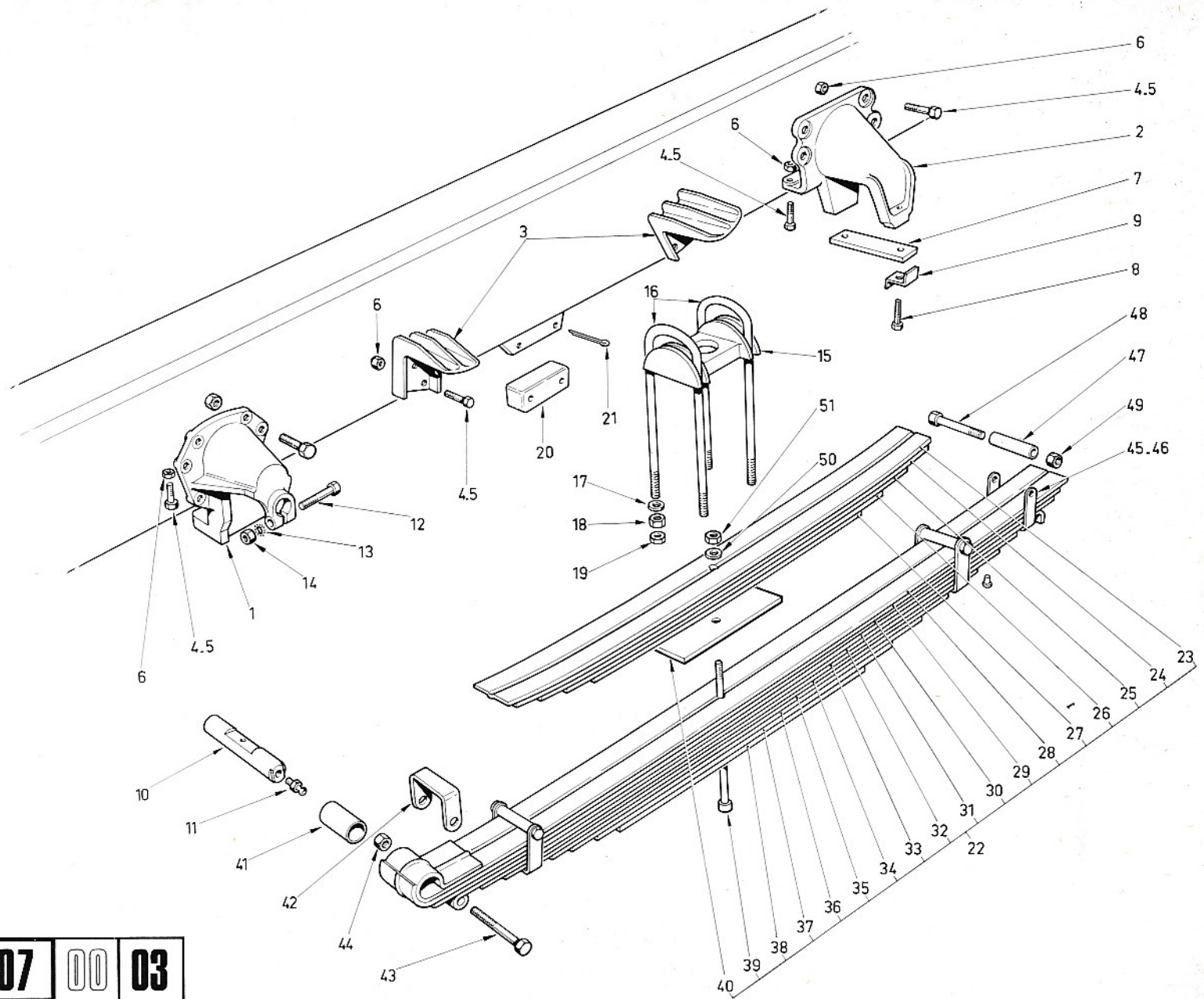

06	66	207	00	03
1	2	3	4	5

6	7	8	9	10
1	61234718	MAIN AVANT	2	
2	61574727	MAIN ARRIERE	2	
3	61111878	BUTEE	4	
4	61803232	VIS	24	
5	61803231	VIS	14	
6	61801356	ECROU	38	
7	61129297	BRIDE	2	
8	61802730	VIS	4	
9	61402011	FREIN	4	
10	61212010	AXE	2	
11	61410502	GRAISSEUR	2	
12	61802699	VIS	2	
13	61815226	RONDELLE	2	
14	61801013	ECROU	2	
15	61574582	SUPPORT	2	
16	61574587	ETRIER	4	
17	61400887	RONDELLE	8	
18	61400090	ECROU	8	
19	61400092	ECROU	8	
20	61118063	BUTEE	2	
21	61819954	GOUPILLE	4	
22	61290960	RESSORT COMPLE	2	
23	61216066	LAME AUX 1	2	
24	61216067	LAME AUX 2	2	
25	61216068	LAME AUX 3	2	

6	7	8	9	10
26	61216069	LAME AUX 4	2	
27	61216070	LAME AUX 5	2	
28	61216055	LAME 1	2	
29	61216056	LAME 2	2	
30	61216057	LAME 3	2	
31	61216058	LAME 4	2	
32	61216059	LAME 5	2	
33	61216060	LAME 6	2	
34	61216061	LAME 7	2	
35	61216062	LAME 8	2	
36	61216063	LAME 9	2	
37	61216064	LAME 10	2	
38	61216065	LAME 11	2	
39	61216072	ETOQUIAU	2	
40	61216071	CALE	2	
41	61212009	BAGUE	2	
42	61216052	ETRIER AVANT	2	
43	61212002	VIS	2	
44	61425010	ECROU	2	
45	61216053	ETRIER CENTRAL	4	
46	61216054	ETRIER ARRIERE	2	
47	61211829	ENTRETOISE	6	
48	61575543	VIS	6	
49	61575544	ECROU	6	
50	61116668	RONDELLE	2	
51	61425035	ECROU	2	

10	11

10	11

Application - Application - Anwendung

Vehicules "Big-Job" tous types

All types "Big-Job" vehicles

Fahrzeug "Big-Job" aller typen

06 66 207 00 03

PLANCHE - PLATE - BLATT

N° modification
Change N°
Änderungsnr.

557

Rep. Mark. Kennzr.	Ancien montage Previous fitting Alte Montage	Pièces supprimées Parts cancelled Entfallende Teile	Nouveau montage New fitting Neue Montage	Désignation Designation Bezeichnung	Quant. Quant. Menge	Code* Code* Code*	Observations Observations Bemerkungen
22	290 960		666 341	Ressort AR complet - RR spring - Feder R	2	1	
23	216 066		236 273	Lame 1 ressort auxiliaire - Leaf 1 - Federblatt 1	2		
24	216 067		236 274	Lame 2 ressort auxiliaire - Leaf 2 - Federblatt 2	2		
25	216 068		236 275	Lame 3 ressort auxiliaire - Leaf 3 - Federblatt 3	2		
26	216 069		236 276	Lame 4 ressort auxiliaire - Leaf 4 - Federblatt 4	2		
27	216 070		236 277	Lame 5 ressort auxiliaire - Leaf 5 - Federblatt 5	2		
28	216 071		236 278	Cale d'épaisseur - Feeler gauge - Fühllehre	2		
29	216 055		236 262	Lame 1 ressort principal - Leaf 1 - Federblatt 1	2		
30	216 056		236 263	Lame 2 ressort principal - Leaf 2 - Federblatt 2	2		
31	216 057		236 264	Lame 3 ressort principal - Leaf 3 - Federblatt 3	2		
32	216 058		236 265	Lame 4 ressort principal - Leaf 4 - Federblatt 4	2		
33	216 059		236 266	Lame 5 ressort principal - Leaf 5 - Federblatt 5	2		
34	216 060		236 267	Lame 6 ressort principal - Leaf 6 - Federblatt 6	2		
35	216 061		236 268	Lame 7 ressort principal - Leaf 7 - Federblatt 7	2		
36	216 062		236 269	Lame 8 ressort principal - Leaf 8 - Federblatt 8	2		
37	216 063		236 270	Lame 9 ressort principal - Leaf 9 - Federblatt 9	2		
38	216 064		236 271	Lame 10 ressort principal - Leaf 10 - Federblatt 10	2		
39	216 065		236 272	Lame 11 ressort principal - Leaf 11 - Federblatt 11	2		

* CODE APPROVISIONNEMENT

- 1 - Anciennes et nouvelles pièces ou ensembles sont interchangeables
- 2 - Anciennes et nouvelles pièces sont interchangeables en ensemble
- 3 - Anciennes et nouvelles pièces ou ensembles ne sont pas interchangeables

* SUPPLY CODE

- 1 - Old and new parts or units are interchangeable
- 2 - Old and new parts are interchangeable in units
- 3 - Old and new parts or units are not interchangeable

* LIEFERUNGSCODE

- 1 - Alte und neue Teile oder Einheiten sind untereinander austauschbar
- 2 - Alte und neue Teile sind als Einheit untereinander austauschbar
- 3 - Alte und neue Teile oder Einheiten sind nicht untereinander austauschbar

camions
UNIC
FIAT

N.D. Ne figure pas sur le dessin.
Not shown on drawing.
Nicht bezeichnet.

Note - Note - Anmerkung

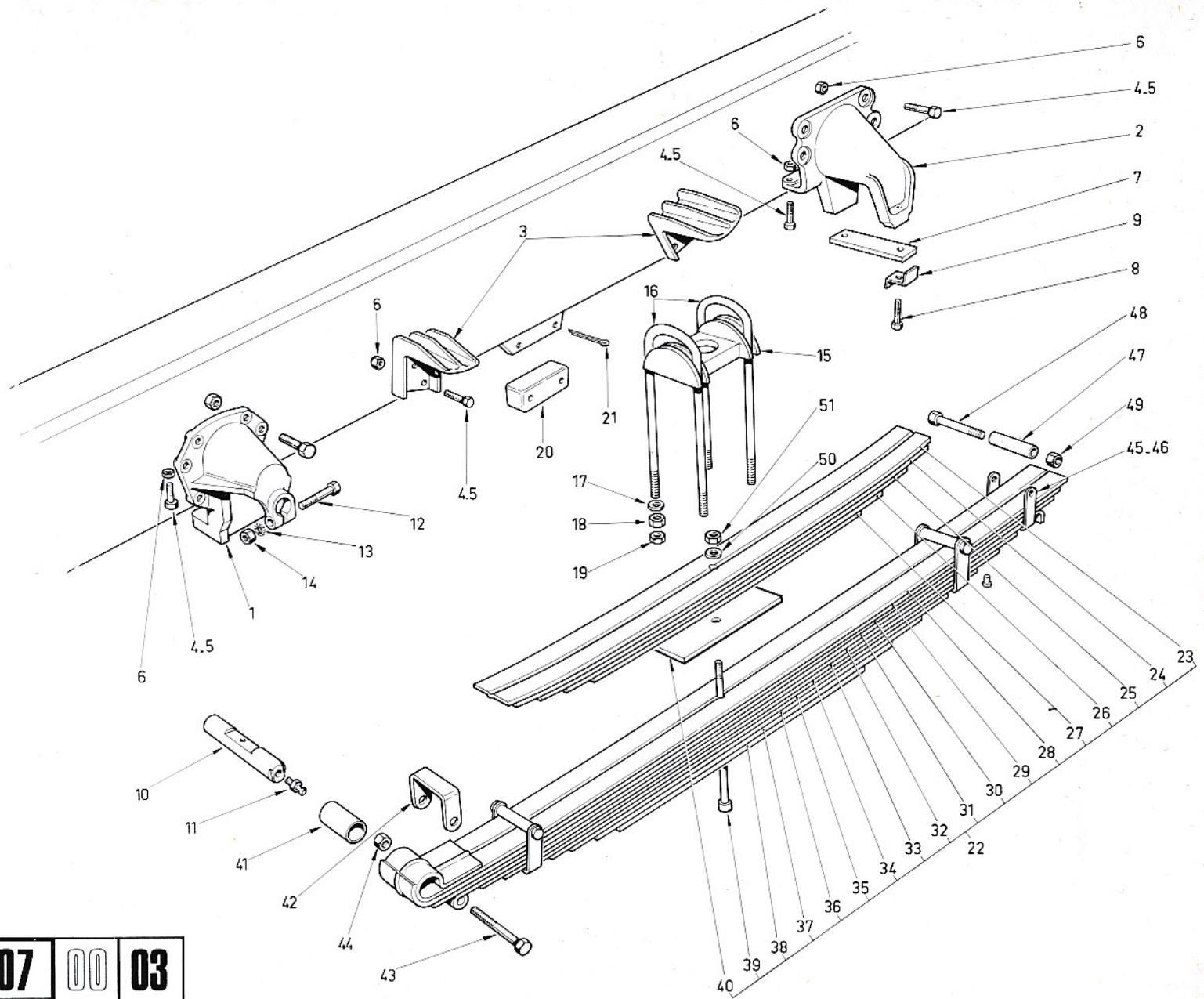

06	66	207	00	03
1	2	3	4	5