

06**ORG. BASE CADRES-SUSPENS.**

FRAMES-SUSPENSIONS BASIC COMPONENT

GRUNDORGAN RAHMEN-RADAUFHÄNGUNG

66**ORG. CADRES-SUSPENSIONS**

FRAMES-SUSPENSIONS COMPONENT

ORGAN RAHMEN-RADAUFHÄNGUNG

206**"BIG-JOB" TRACTEURS 6 CYL.****"BIG-JOB" TRACTOR 6 CYL.****"BIG-JOB" SCHLEPPER 6 ZYL.**

CATALOGUE RELEVÉ AU : 16 - 5 - 72

CSA châssis N° 112-266
"BIG-JOB"

CATALOG ACCOUNTING AS OF 16-5-72

"BIG-JOB" chassis N° 112-266
cab

KATALOGAUSZUG ZUM 16 - 5 - 72

"BIG-JOB" chassis Nr 112-266
kurzhauber**06****66****206**N° EDITION
CATALOGUEN° DE
PLANCHE

1

2

3

4

5

Cadre de châssis	00	01
<i>Frame</i>		
<i>Rahmen</i>		
Suspension avant	00	02
<i>Front suspension</i>		
<i>Vorderradaufhängung</i>		
Suspension arrière	00	03
<i>Rear suspension</i>		
<i>Hinterradaufhängung</i>		
Suspension arrière	00	04
<i>Rear suspension</i>		
<i>Hinterradaufhängung</i>		
Suspension moteur (L 63 S)	00	05
<i>Power plant supports (L 63 S)</i>		
<i>Triebwerklager (L 63 S)</i>		

1	ORGANE DE BASE	BASIC COMPONENT	GRUND-ORGAN
2	ORGANE	COMPONENT	ORGAN
3	TYPE D'ORGANE	COMPONENT TYPE	ORGANTYP
4	N° ÉDITION	CATAL. EDITION NUMBER	NUMMER DER AUSGABE
5	N° PLANCHE	PLATE NUMBER	BILD Nr.
6	REPÈRE	MARKING	KENNZIFFER

7	N° PIÈCE	PART N°	TEIL Nr.
8	DÉSIGNATION	DESIGNATION	BESCHRIFTUNG
9	QUANTITÉ	QUANTITY	MENGE
10	CODE OBSERVATIONS	CODE OF OBSERV.	ANMERKUNGEN KODE
11	DÉTAILS OBSERVATIONS	DETAILS OF OBSERV.	ANMERKUNGEN BEDEÜT.

Référence: 655.634
 Kennzahl:
 Edition: 15-7-72
 Ausgabe:

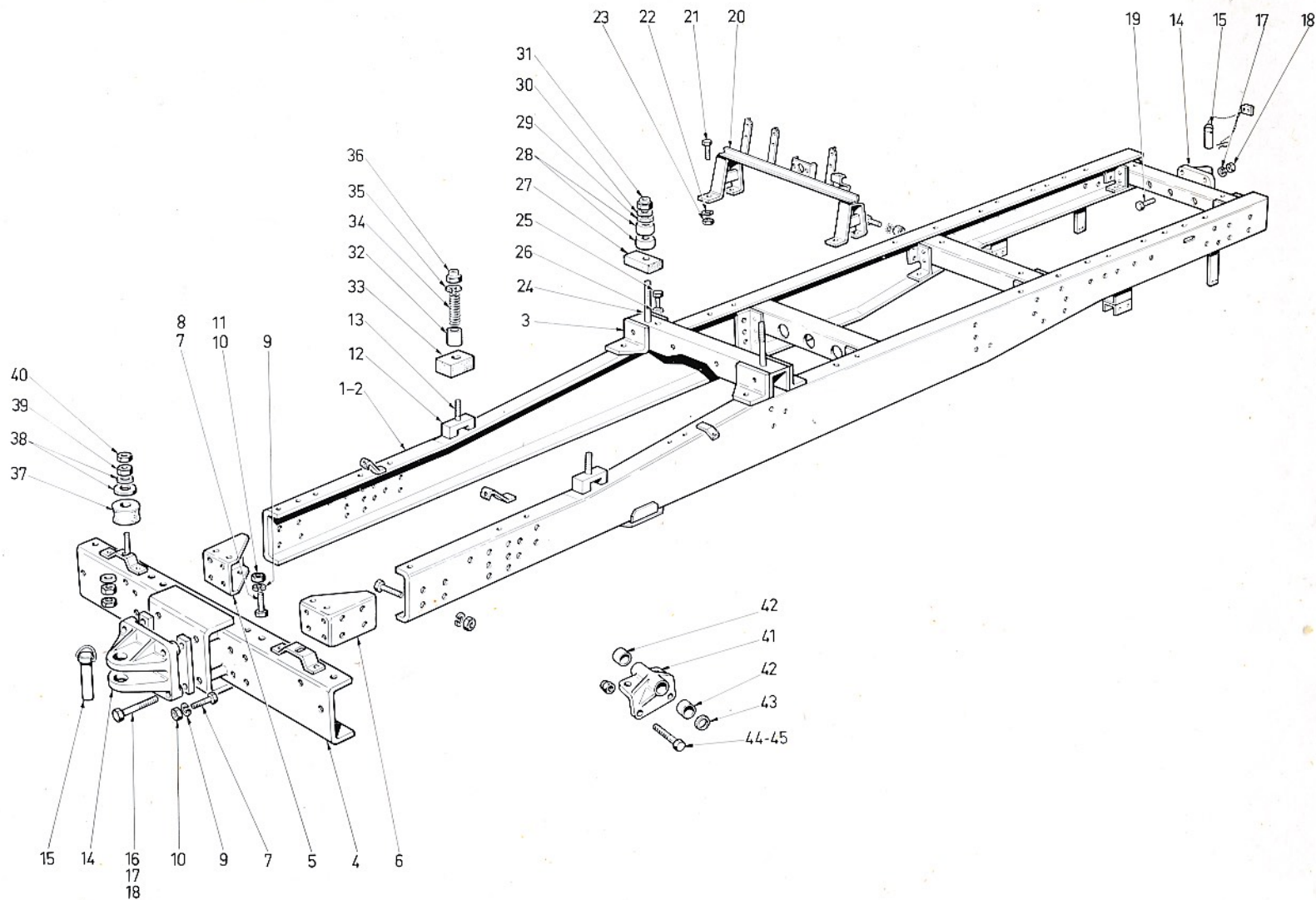

06	66	206	00	01
1	2	3	4	5

6	7	8	9	10
1	61657931	CADRE T 220	1	
2	61664765	CADRE T 10S6	1	
3	61298434	TRAVERSE	1	
4	61291326	TRAVERSE AVANT	1	
5	61216666	GOUSSET DROIT	1	
6	61216667	GOUSSET GAUCHE	1	
7	61803189	VIS	20	
8	61803192	VIS	4	
9	61815247	RONDELLE	24	
10	61801013	ECROU	20	
11	61801355	ECROU	4	
12	61132454	SUPPORT	2	
13	61803206	VIS	2	
14	61217007	CHAPE	2	
15	61127168	AXE	2	
16	61803282	VIS	4	
17	61815249	RONDELLE	8	
18	61801015	ECROU	8	
19	61803272	VIS	4	
20	61658084	SUPPORT ASS	1	
21	61802647	VIS	4	
22	61815306	RONDELLE	4	
23	61801012	ECROU	4	
24	61657961	VIS	2	
25	61803917	VIS	2	

10	11

6	7	8	9	10
26	61815303	RONDELLE	2	
27	61203545	CALE	2	
28	61117743	CALE	4	
29	61220361	RONDELLE	2	
30	61077378	RONDELLE	2	
31	61801355	ECROU	2	
32	61132895	ENTRETOISE	2	
33	61240588	BLOC	2	
34	61132894	RESSORT	2	
35	61238496	RONDELLE	2	
36	61801355	ECROU	2	
37	61234244	PLOT	2	
38	61815040	RONDELLE	4	
39	61801012	ECROU	4	
40	61801705	ECROU	4	
41	61666378	SUPPORT ASS	1	
42	61236151	BAGUE	2	
43	61224667	JOINT	1	
44	61803191	VIS	4	
45	61801355	ECROU	4	

10	11

06 66 206 00 02



DÉSIGNATION PLANCHE : SE RÉFÉRER AUX PAGES "SOMMAIRE"

PLATE DESIGNATION : REFER TO FLYLEAF

BILDBESCHRIFTUNG : SIEHE VORSATZBLÄTTER



1	2	3	4	5
---	---	---	---	---

6	7	8	9	10
1	61239276	MAIN	4	781
2	61239277	MAIN	4	
3	61230296	CALE	2	
4	61803275	VIS	8	
5	61803272	VIS	8	
6	61801357	ECROU	16	
7	61668819	JUMELLE ASS	2	781
8	61668818	JUMELLE ASS	2	
9	61211834	BAGUE	4	781
10	61212721	BAGUE	4	
11	61211835	AXE RESSORT	6	781
12	61212719	AXE RESSORT	6	
13	61802696	VIS	6	
14	61815226	RONDELLE	6	
15	61801013	ECROU	6	
16	61410502	GRAISSEUR	4	
17	61410514	GRAISSEUR	2	
18	61217184	SUPPORT GAUCHE	1	781
19	61217186	SUPPORT DROIT	1	781
20	61217183	SUPPORT GAUCHE	1	
21	61217185	SUPPORT DROIT	1	
22	61218276	BUTEE	2	
23	61116500	ETRIER	4	781
24	61212756	ETRIER	4	
25	61815010	RONDELLE	8	781

6	7	8	9	10
26	61400070	ECROU	8	781
27	61400072	ECROU	8	781
28	61815009	RONDELLE	8	
29	61095033	ECROU	8	
30	61211832	CALE	2	781
31	61234187	BUTEE	2	781
32	61234188	BUTEE	2	
33	61802690	VIS	4	
34	61815247	RONDELLE	4	
35	61801013	ECROU	4	
36	61668644	RESSORT 10LAME	2	781
37	61578319	LAME 1	2	781
38	61239295	LAME 2	2	781
39	61239296	LAME 3	2	781
40	61239297	LAME 4	2	781
41	61211821	LAME 5	2	781
42	61211822	LAME 6	2	781
43	61211823	LAME 7	2	781
44	61573714	LAME 8	2	781
45	61211825	LAME 9	2	781
46	61573715	LAME 10	2	781
47	61211830	ETOQUIAU	2	781
48	61115885	RONDELLE	2	
49	61115886	RONDELLE	2	
50	61425033	ECROU	2	

10	11
0781	Châssis T220 Chassis T220 Fahrgestell T220

10	11

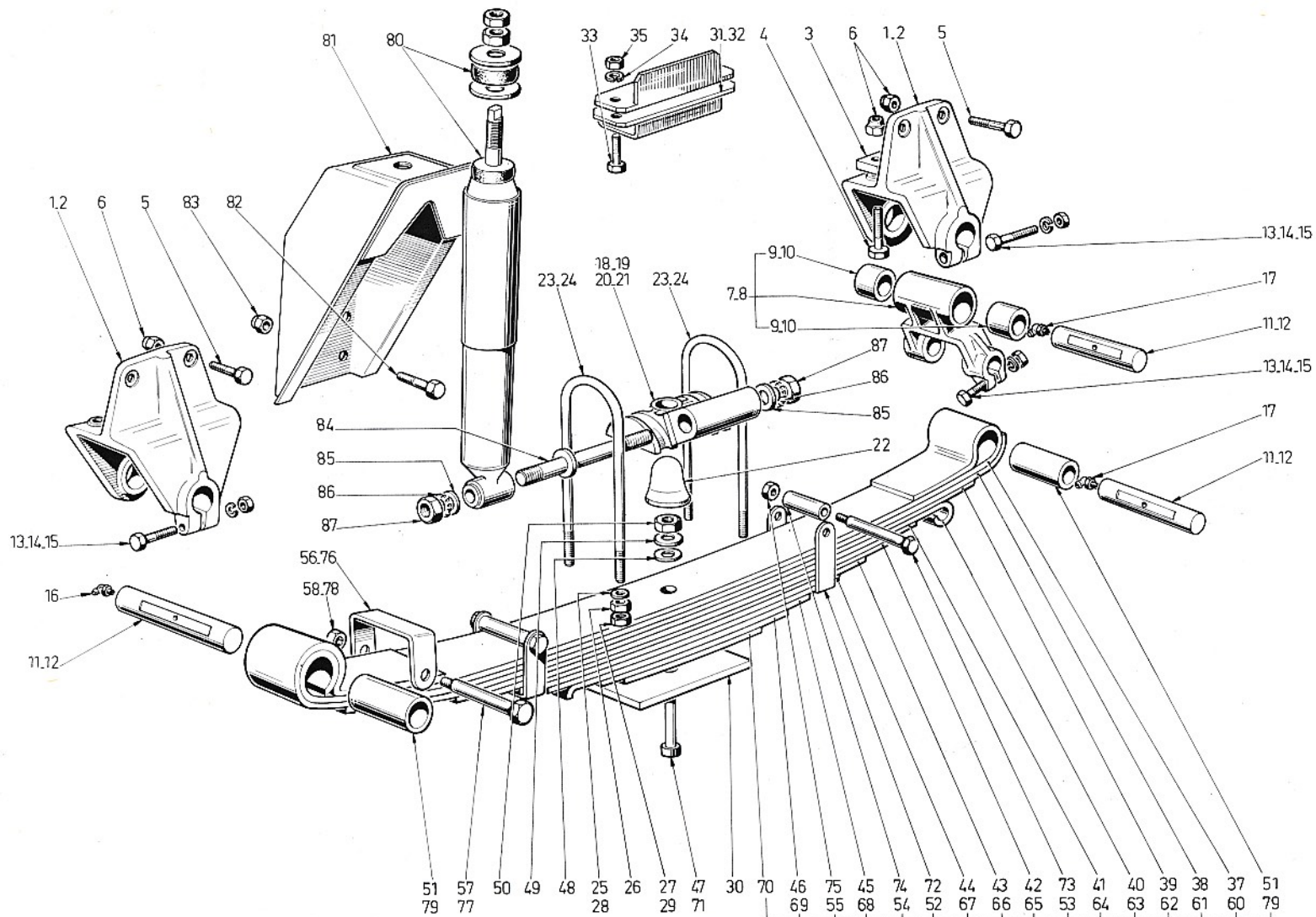

36.59

06	66	206	00	02
1	2	3	4	5

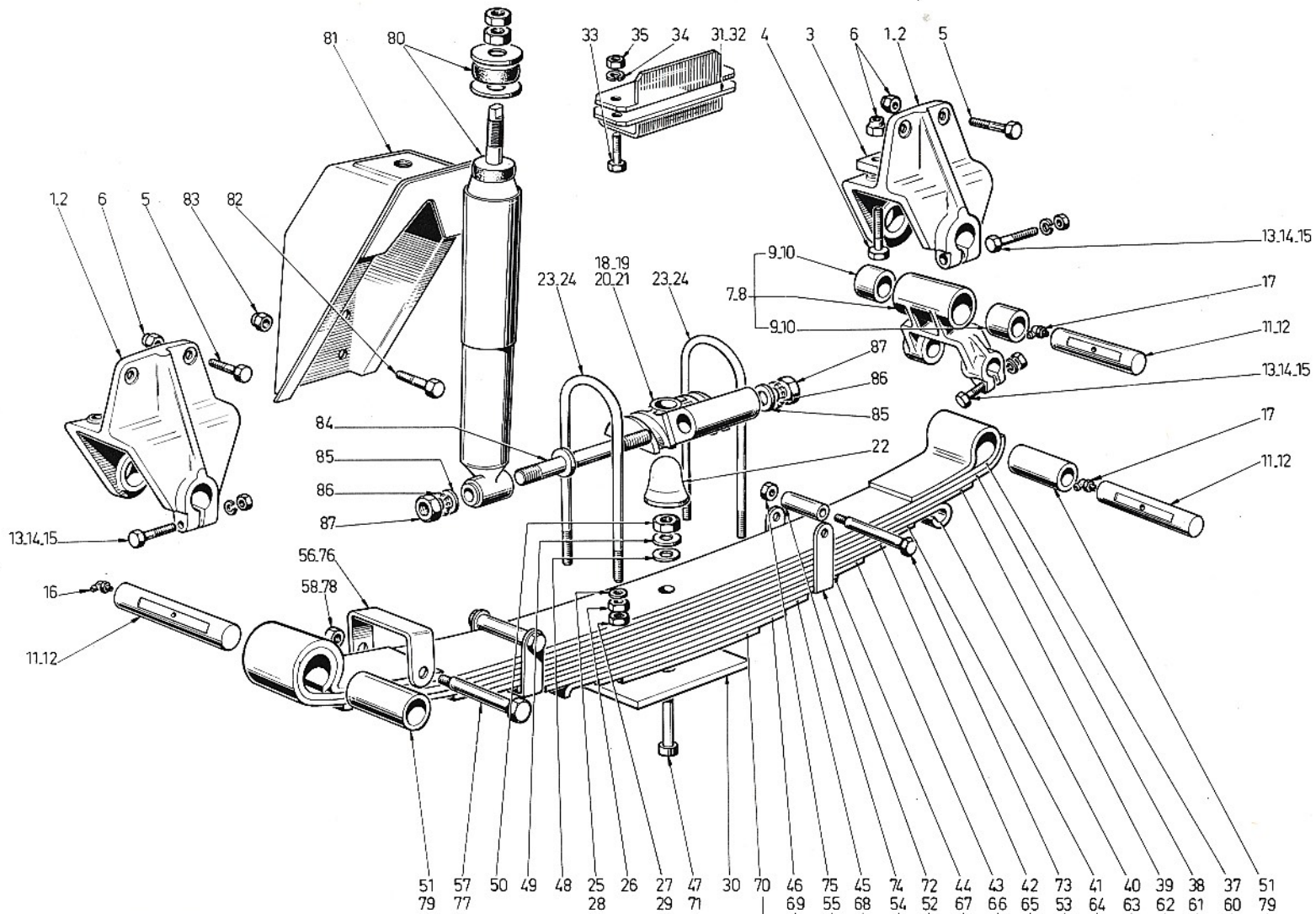

06	66	206	00	02
1	2	3	4	5

36.59

6	7	8	9	10
51	61117593	BAGUE RESSORT	4	781
52	61211827	BRIDE	4	781
53	61803285	AXE	4	781
54	61211829	ENTRETOISE	4	781
55	61801015	ECROU	4	781
56	61239294	BRIDE	4	781
57	61575543	AXE	4	781
58	61575544	ECROU	4	781
59	61668650	RESSORT 11LAME	2	
60	61578320	LAME 1	2	
61	61239326	LAME 2	2	
62	61239327	LAME 3	2	
63	61239328	LAME 4	2	
64	61217359	LAME 5	2	
65	61217360	LAME 6	2	
66	61217361	LAME 7	2	
67	61217362	LAME 8	2	
68	61573712	LAME 9	2	
69	61217364	LAME 10	2	
70	61573713	LAME 11	2	
71	61212754	ETOQUIAU	2	
72	61216786	BRIDE	4	
73	61207252	AXE	4	
74	61207251	ENTRETOISE	4	
75	61425007	ECROU	4	

6	7	8	9	10
76	61239325	BRIDE	4	
77	61803283	AXE	4	
78	61801015	ECROU	4	
79	61212720	BAGUE	4	
80	61253779	AMORTISSEUR	2	
81	61293363	SUPPORT ASS	2	
82	61803189	VIS	8	
83	61801355	ECROU	8	
84	61217121	AXE	2	
85	61815010	RONDELLE	4	
86	61400964	RONDELLE	4	
87	61801070	ECROU	4	

10	11
0781	Châssis T220 Chassis T220 Fahrgestell T220

10	11

06	66	206	00	03
1	2	3	4	5



DÉSIGNATION PLANCHE : SE RÉFÉRER AUX PAGES "SOMMAIRE"
 PLATE DESIGNATION : REFER TO FLYLEAF
 BILDBESCHRIFTUNG : SIEHE VORSATZBLÄTTER



6	7	8	9	10
1	61234789	MAIN AVANT	2	
2	61234718	MAIN AVANT	2	781
3	61574727	MAIN ARRIERE	2	
4	61111878	BUTEE	4	
5	61803232	VIS	24	
6	61803231	VIS	14	
7	61801356	ECROU	38	
8	61129297	BRIDE	2	
9	61802730	VIS	4	
10	61402011	FREIN	4	
11	61115227	AXE	2	
12	61212010	AXE	2	781
13	61410502	GRAISSEUR	2	
14	61802699	VIS	2	
15	61815226	RONDELLE	2	
16	61801013	ECROU	2	
17	61115663	SUPPORT	2	
18	61574582	SUPPORT	2	781
19	61212964	ETRIER	4	
20	61574588	ETRIER	4	781
21	61400869	RONDELLE	8	
22	61400080	ECROU	8	
23	61400082	ECROU	8	
24	61400887	RONDELLE	8	781
25	61400090	ECROU	8	781

6	7	8	9	10
26	61400092	ECROU	8	781
27	61118063	BUTEE	2	
28	61819954	GOUPILLE	4	
29	61276755	RESSORT COMPL	2	
30	61211961	LAME AUX 1	2	
31	61211962	LAME AUX 2	2	
32	61211963	LAME AUX 3	2	
33	61211964	LAME AUX 4	2	
34	61211965	LAME AUX 5	2	
35	61211966	LAME 1	2	
36	61211967	LAME 2	2	
37	61211968	LAME 3	2	
38	61211969	LAME 4	2	
39	61211970	LAME 5	2	
40	61211971	LAME 6	2	
41	61211972	LAME 7	2	
42	61211973	LAME 8	2	
43	61211974	LAME 9	2	
44	61211975	LAME 10	2	
45	61211976	LAME 11	2	
46	61211977	LAME 12	2	
47	61211978	LAME 13	2	
48	61212004	ETOQUIAU	2	
49	61115925	RONDELLE	2	
50	61425033	ECROU	2	

10	11
0781	Châssis T220 Chassis T220 Fahrgestell T220

10	11

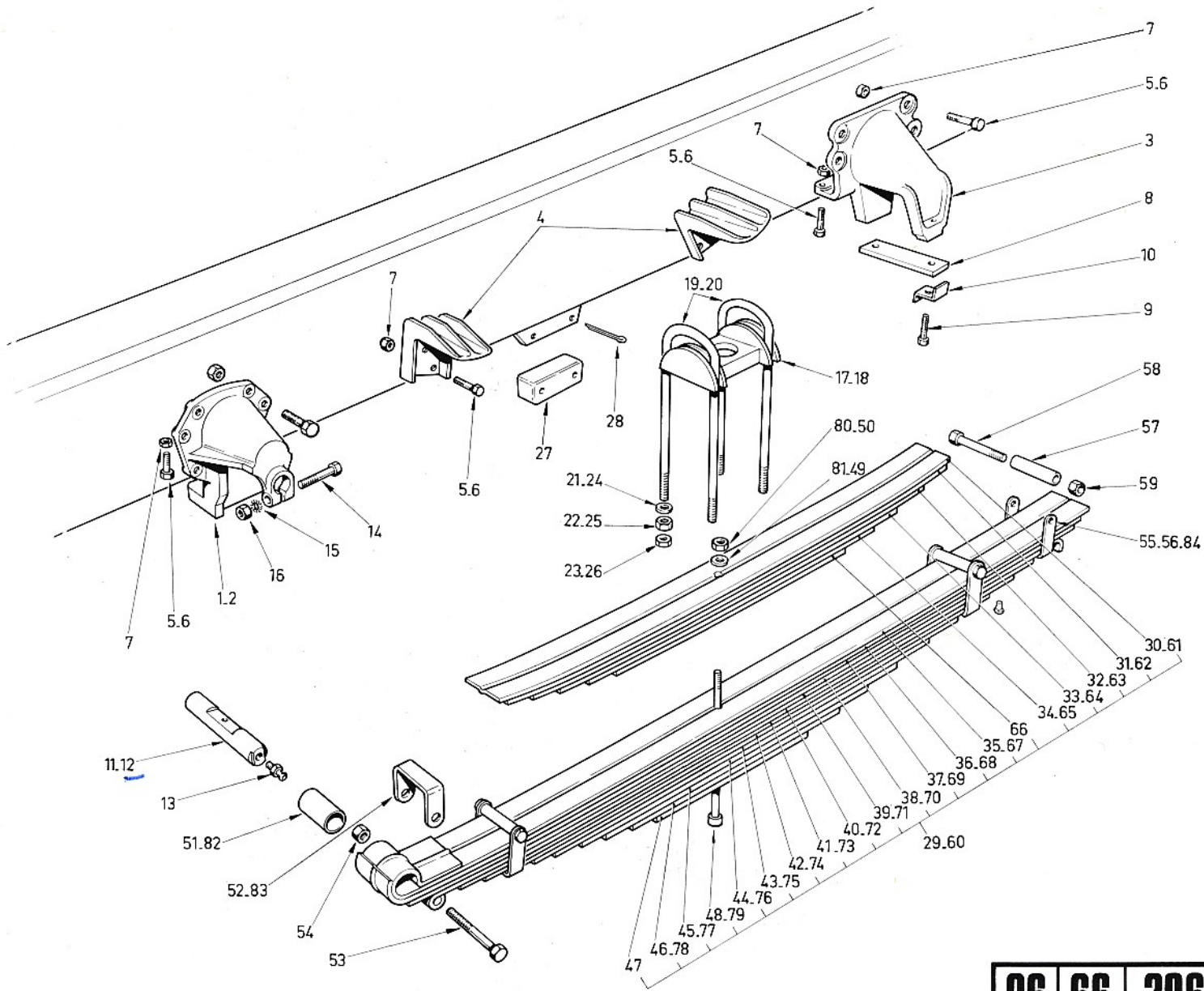

06	66	206	00	03
1	2	3	4	5

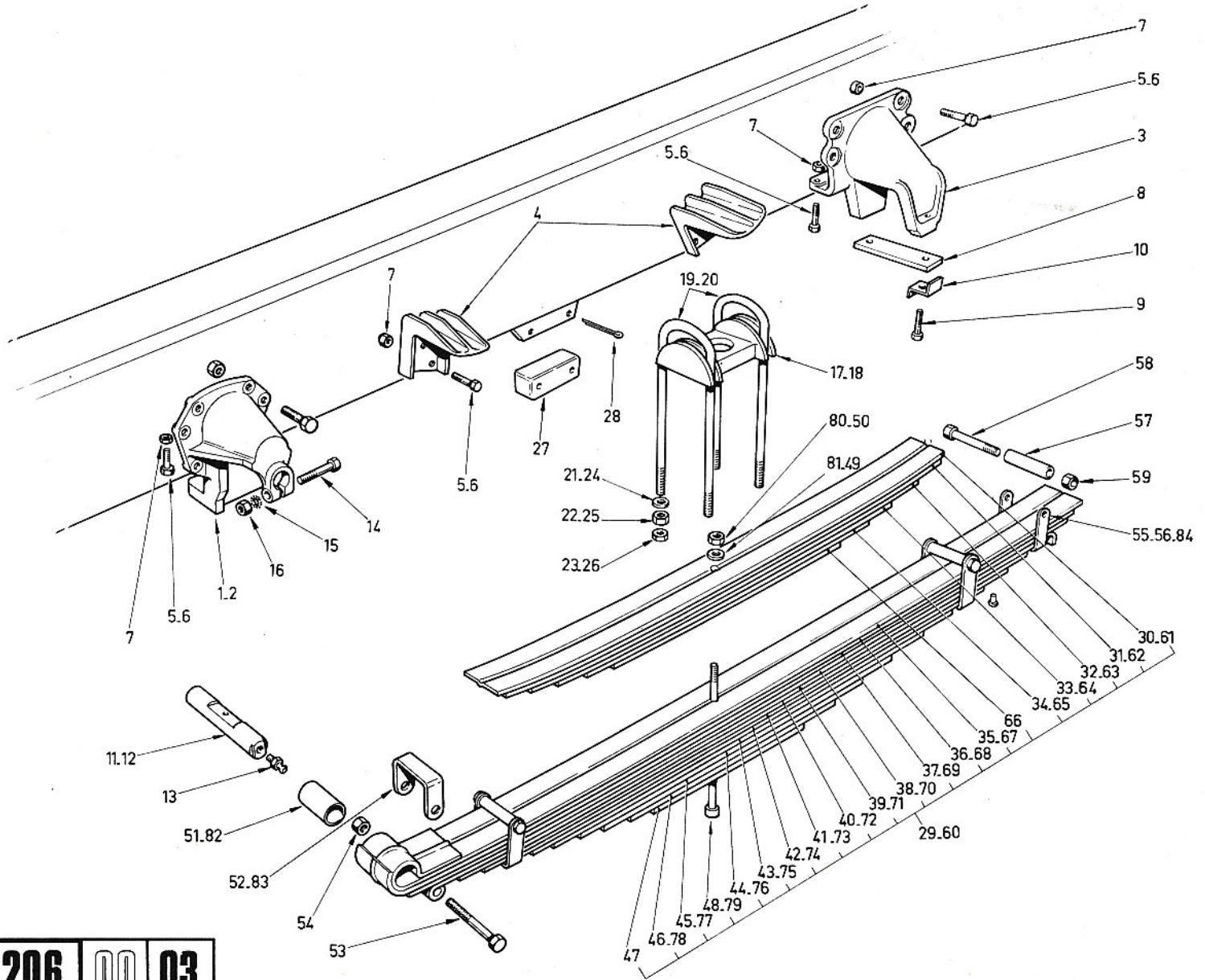

06	66	206	00	03
1	2	3	4	5

6	7	8	9	10
51	61117593	BAGUE	2	
52	61212007	ETRIER	2	
53	61212002	VIS	2	
54	61425010	ECROU	2	
55	61211998	ETRIER CENTRAL	4	
56	61212001	ETRIER ARRIERE	2	
57	61211829	ENTRETOISE	6	
58	61575543	VIS	6	
59	61575544	ECROU	6	
60	61276756	RESSORT COMPL	2	781
61	61211979	LAME AUX 1	2	781
62	61211980	LAME AUX 2	2	781
63	61211981	LAME AUX 3	2	781
64	61211982	LAME AUX 4	2	781
65	61211983	LAME AUX 5	2	781
66	61211984	LAME AUX 6	2	781
67	61211985	LAME 1 -	2	781
68	61211986	LAME 2	2	781
69	61211987	LAME 3	2	781
70	61211988	LAME 4 -	2	781
71	61211989	LAME 5	2	781
72	61211990	LAME 6	2	781
73	61211991	LAME 7	2	781
74	61211992	LAME 8	2	781
75	61211993	LAME 9	2	781

6	7	8	9	10
76	61211994	LAME 10	2	781
77	61211995	LAME 11	2	781
78	61211996	LAME 12	2	781
79	61212005	ETOQUIAU	2	781
80	61425035	ECROU	2	781
81	61116668	RONDELLE	2	781
82	61212009	BAGUE	2	781
83	61212008	ETRIER AVANT	2	781
84	61211997	ETRIER ARRIERE	2	781

10	11
0781	Châssis T220 Chassis T220 Fahrgestell T220

10	11

06 66 206 00 04

1 2 3 4 5

DÉSIGNATION PLANCHE : SE RÉFÉRER AUX PAGES "SOMMAIRE"
 PLATE DESIGNATION : REFER TO FLYLEAF
 BILDBESCHRIFTUNG : SIEHE VORSATZBLÄTTER



6	7	8	9	10
1	61230263	TOLE GAUCHE	1	
2	61230264	TOLE DROITE	1	
3	61803230	VIS	2	
4	61801356	ECROU	2	
5	61803233	VIS	2	
6	61801356	ECROU	2	
7	61803275	VIS	4	
8	61801357	ECROU	4	
9	61233495	SUPPORT AVANT	2	
10	61803150	VIS	8	
11	61801354	ECROU	8	
12	8541489	SILENT BLOC	2	
13	61803187	VIS	2	
14	61815226	RONDELLE	2	
15	61815226	RONDELLE	2	
16	61801033	ECROU	2	
17	61664211	ETRIER	2	
18	61233152	PLAQUE	2	
19	61233153	BUTEE	2	
20	61815225	RONDELLE	4	
21	61801012	ECROU.	4	
22	61801354	ECROU	4	
23	61230261	TOLE GAUCHE	1	
24	61230262	TOLE DROITE	1	
25	61803190	VIS	7	

6	7	8	9	10
26	61801355	ECROU	7	
27	8536261	SUPPORT	2	
28	61803151	VIS	8	
29	61801354	ECROU	8	
30	8536262	SILENT BLOC	2	
31	61803146	VIS	4	
32	61815225	RONDELLE	4	
33	61234142	AXE	2	
34	61231428	RONDELLE	2	
35	61801357	ECROU	2	

10	11

10	11

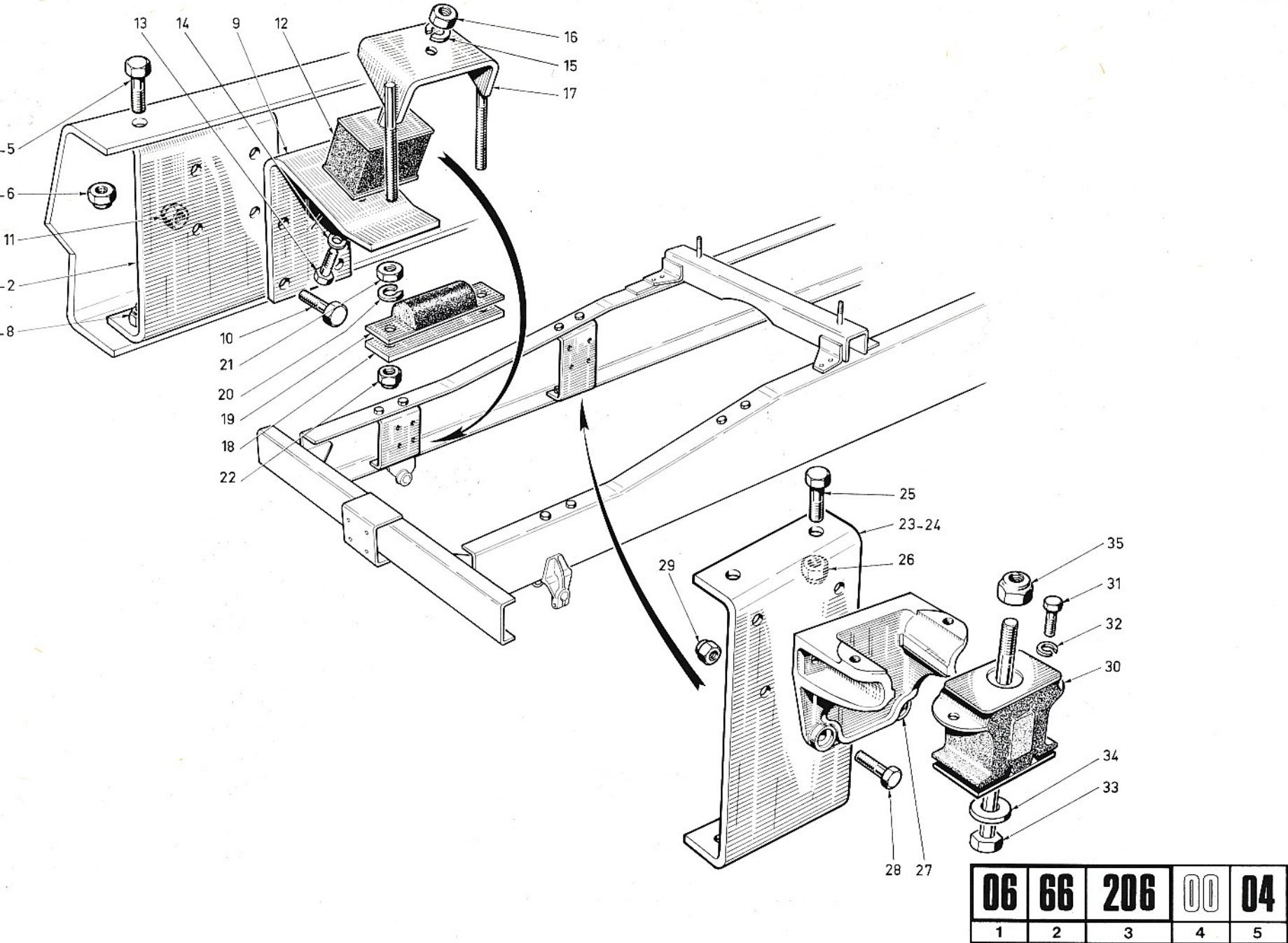

06	66	206	00	04
1	2	3	4	5

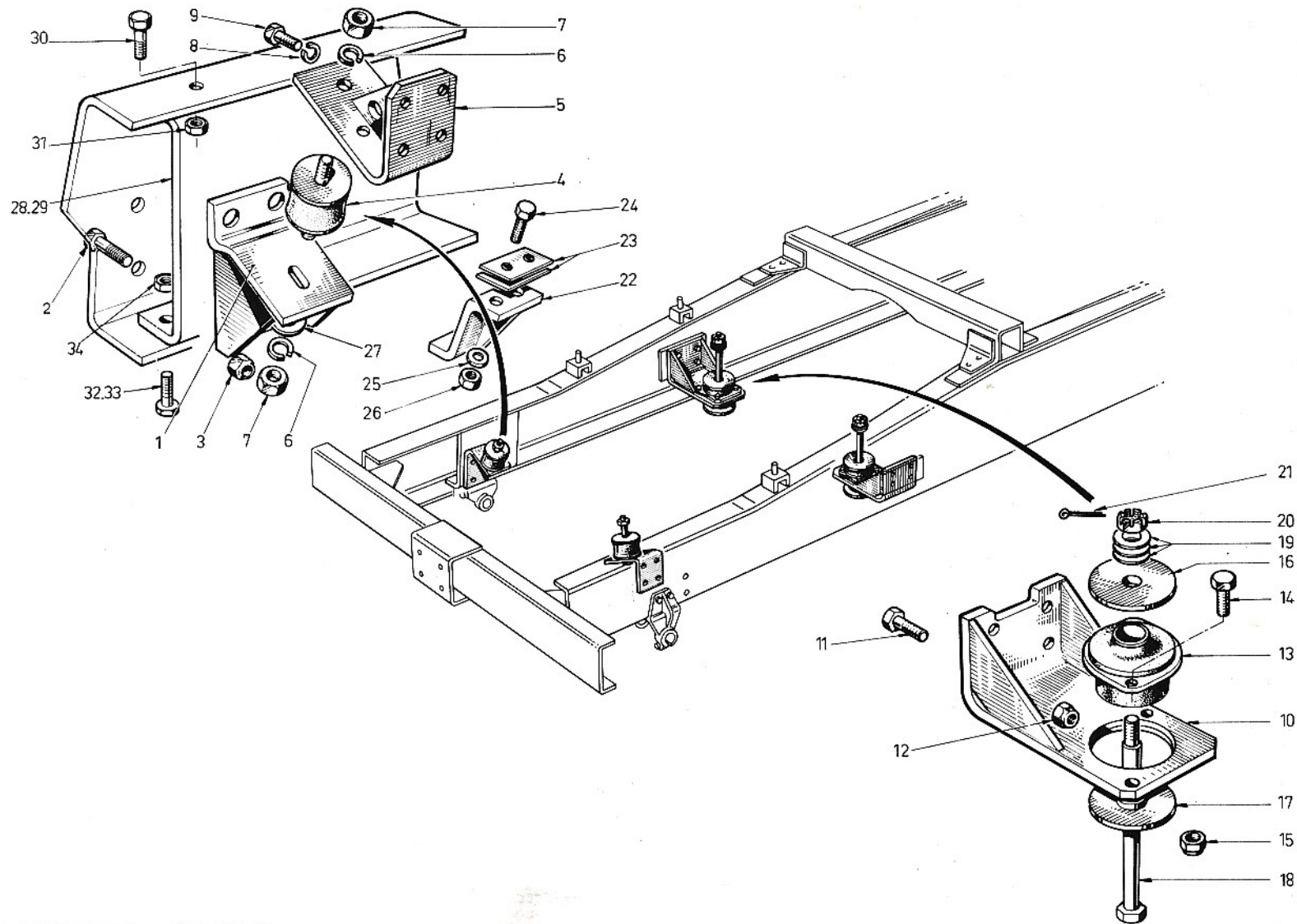

06	66	206	00	05
1	2	3	4	5

6	7	8	9	10
1	61237131	SUPPORT AVANT	2	
2	61803149	VIS	8	
3	61801354	ECROU	8	
4	61235421	ELEMENT	2	
5	61227527	SUPPORT	2	
6	61815225	RONDELLE	4	
7	61225310	ECROU	4	
8	61815226	RONDELLE	8	
9	61803187	VIS	8	
10	61232538	SUPPORT	2	
11	61803190	VIS	8	
12	61801355	ECROU	8	
13	61235172	ELEMENT	2	
14	61803149	VIS	4	
15	61801354	ECROU	4	
16	61233150	RONDELLE	2	
17	61230305	RONDELLE	2	
18	61225017	AXE	2	
19	61815007	RONDELLE		68
20	61520014	ECROU	2	
21	61819922	GOUPILLE	2	
22	61236462	LIMITEUR	2	
23	61231224	CALE		68
24	61803150	VIS	4	
25	61815005	RONDELLE	4	

10	11
0068	Quantités : au choix Quantities : as desired Mengen : nach Wahl

6	7	8	9	10
26	61801354	ECROU	4	
27	61815057	RONDELLE	2	
28	61237129	TOLE GAUCHE	1	
29	61237130	TOLE DROITE	1	
30	61803230	VIS	2	
31	61801356	ECROU	2	
32	61803272	VIS	4	
33	61803275	VIS	4	
34	61801357	ECROU	8	

10	11