

**06****ORGANE CADRES - SUSPENSIONS**

FRAMES SUSPENSIONS COMPONENT

ORGAN RAHMEN RADAUFHÄNGUNG

**06****66****201**N° EDITION  
CATALOGUEN° DE  
PLANCHE**1****2****3****4****5****66****SOUS-ORGANE CADRES - SUSPENS.**

FRAMES SUSPENSIONS SUB-COMPONENT

UNTER-ORGAN RAHMEN RADAUFHÄNG.

**201****CABINE C.50 CHASSIS PORTEURS**

C.50 CAB CARRIER CHASSIS

FAHRERHAUS C.50 LASTWAGEN

VALIDITÉ DE LA  
VARIANTE D'ORGANEVARIANT  
COMPONENT  
APPLICABILITYABGELEITETE  
GÜLTIGKEIT

TYPE DE CHASSIS CHASSIS TYPE FAHRGESTELL TYP	N° DE CHASSIS CHASSIS Nr. FAHRGESTELL Nr.
<b>P 6</b>	<b>68.602</b>
<b>P 8R</b>	<b>91.930</b>
<b>P 9</b>	<b>91.932</b>

Cadre de châssis .....

*Chassis frame**Fahrgestellrahmen*

00

01

Suspension avant .....

*Front suspension**Vorderradaufhängung*

00

02

Suspension arrière .....

*Rear suspension**Hinterradaufhängung*

00

03

Suspension moteur .....

*Engine housing**Motorenhalterung*

00

04

1	ORGANE	COMPONENT	ORGAN
2	SOUS-ORGANE	SUB-COMPONENT	UNTER-ORGAN
3	VARIANTE D'ORGANE	VARIANT COMPONENT	ABGELEITETE ORGAN
4	N° EDITION	CATAL. EDIT. NUMBER	NUMMER DER AUSGABE
5	N° PLANCHE	PLATE NUMBER	BILD Nr.
6	REPERE	MARKING	KENNZIFFER

7	N° PIECE	PART N°	TEIL Nr.
8	DESIGNATION	DESIGNATION	BESCHRIFTUNG
9	QUANTITE	QUANTITY	MENGE
10	CODE OBSERVATIONS	CODE OF OBSERV.	ANMERKUNGEN KODE
11	DETAILS OBSERVATIONS	DETAILS OF OBSERV.	ANMERKUNGEN BEDEUT.

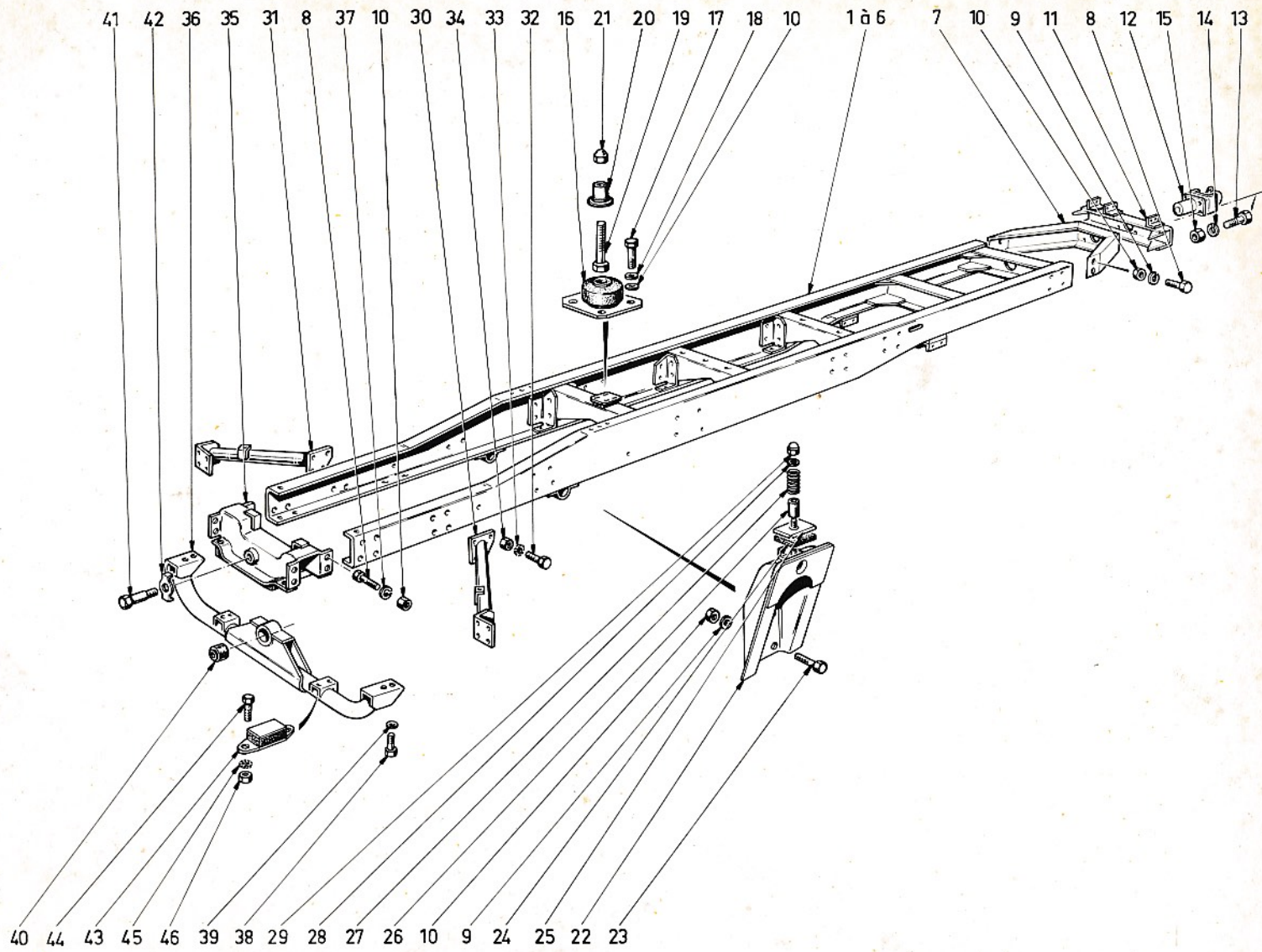

<b>06</b>	<b>66</b>	<b>201</b>	<b>00</b>	<b>01</b>
1	2	3	4	5

6	7	8	9	10
1	61664104	CADRE 4M400	1	
2	61664105	CADRE 4M750	1	
3	61664106	CADRE 3M750	1	
4	61664107	CADRE 4M400	1	
5	61664108	CADRE 4M750	1	
6	61664109	CADRE 3M750	1	
7	61218C83	TIRANT	1	
8	61803189	VIS TH	16	
9	61815247	RONDELLE	12	
10	61801013	ECROU H	28	
11	61217431	RENFORT	1	
12	61291602	CROCHET	1	
13	61803274	VIS TH	4	
14	61801C15	RONDELLE	4	
15	61801C68	ECROU	4	
16	61235107	SUPPORT	1	
17	61803187	VIS	4	
18	61815336	RONDELLE	4	
19	61520158	VIS TH	1	
20	61655844	BUTEE	1	
21	61520159	ECROU H	1	
22	61657956	SUPPORT AV	1	
23	61802687	VIS TH	8	
24	61240661	CAOUTCHOUC	2	
25	61203679	COUPELLE	2	

10	11

6	7	8	9	10
26	61235191	ENTRETOISE	2	
27	61132894	RESSORT	2	
28	61238496	RONDELLE	2	
29	61801355	ECROU	2	
30	61248071	TIRANT G ASS	1	
31	61248072	TIRANT D ASS	1	
32	61802647	VIS TH	14	
33	61815306	RONDELLE	14	
34	61801012	ECROU	14	
35	61658010	TRAVERSE AV AS	1	
36	61247820	SUPPORT AV ASS	1	
37	61815226	RONDELLE	12	
38	61803147	VIS TH	4	
39	61815335	RONDELLE	4	
40	61711674	SILENT BLOC	1	
41	61711507	AXE	1	
42	61711506	FREIN AXE	1	
43	61234876	BUTEE ELASTIQU	2	
44	61802605	VIS TH	4	
45	61815305	RONDELLE	4	
46	61801011	ECROU H	4	

10	11

**06 66 201 00 02**

DÉSIGNATION PLANCHE : SE RÉFÉRER AUX PAGES "SOMMAIRE"  
 PLATE DESIGNATION : REFER TO FLYLEAF  
 BILDBESCHRIFTUNG : SIEHE VORSATZBLÄTTER



6	7	8	9	10
1	61236357	SUPPORT	4	
2	61803190	VIS LON 35	10	
3	61803192	VIS LON 45	2	
4	61801355	ECROU	12	
5	61666856	JUMELLE ASS	2	
6	61574906	BAGUE	2	
7	61211493	AXE	6	
8	61820647	GOUPILLE	6	
9	61410514	GRAISSEUR	6	
10	61659664	RESSORT ASS10L	2	
11	61207198	LAME NO 1	2	
12	61207199	LAME NO 2	2	
13	61211692	LAME NO 3	2	
14	61211693	LAME NO 4	2	
15	61211694	LAME NO 5	2	
16	61211695	LAME NO 6	2	
17	61211696	LAME NO 7	2	
18	61211697	LAME NO 8	2	
19	61211698	LAME NO 9	2	
20	61211699	LAME NO 10	2	
21	61666885	RESSORT ASS 9L	2	
22	61207189	LAME NO 1	2	
23	61207190	LAME NO 2	2	
24	61207191	LAME NO 3	2	
25	61207192	LAME NO 4	2	

6	7	8	9	10
26	61207193	LAME NO 5	2	
27	61207194	LAME NO 6	2	
28	61207195	LAME NO 7	2	
29	61207196	LAME NO 8	2	
30	61207197	LAME NO 9	2	
31	61229945	BAGUE	4	
32	61211689	ETOQUIAU	2	245
33	61207185	ETOQUIAU	2	246
34	61490285	ECROU	2	
35	61211690	BRIDE	4	245
36	61207187	BRIDE	4	246
37	61700996	ENTRETOISE	4	
38	61706399	AXE	4	
39	61425007	ECROU	4	
40	61408373	RIVET	4	
41	61211691	ETRIER	4	245
42	61207208	ETRIER	4	246
43	61210228	PLAQUE	2	
44	61815249	RONDELLE	8	
45	61702114	ECROU	8	
46	61657956	SUPPORT	2	
47	61802687	VIS	8	
48	61815247	RONDELLE	8	
49	61801013	ECROU	8	
50	61211064	SUPPORT	2	

10	11
245	Châssis - P8 - P8R - P9 Chassis - P8 - P8R - P9 Chassis - P8 - P8R - P9
246	Châssis - P6 Chassis - P6 Chassis - P6

10	11

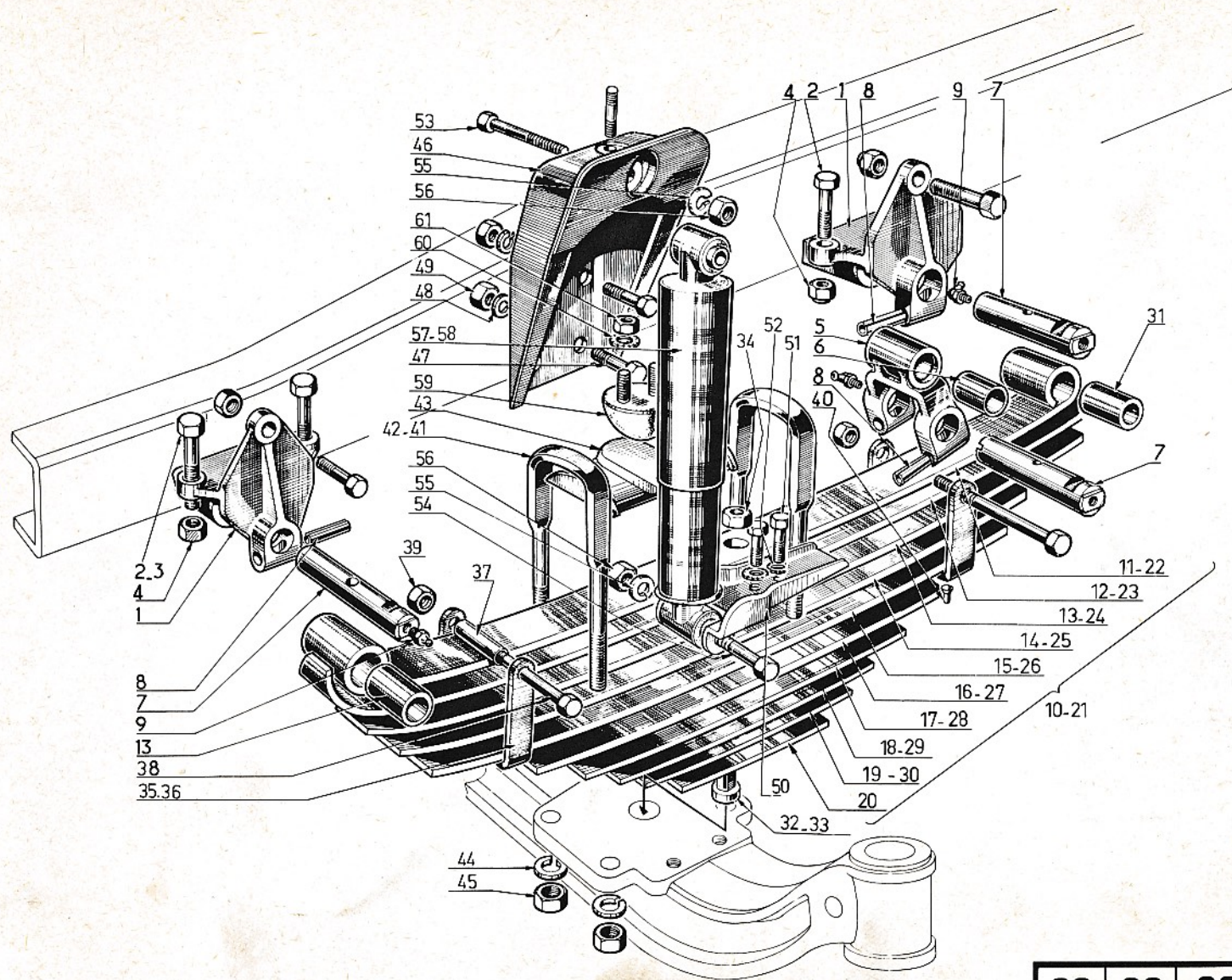

<b>06</b>	<b>66</b>	<b>201</b>	<b>00</b>	<b>02</b>
1	2	3	4	5

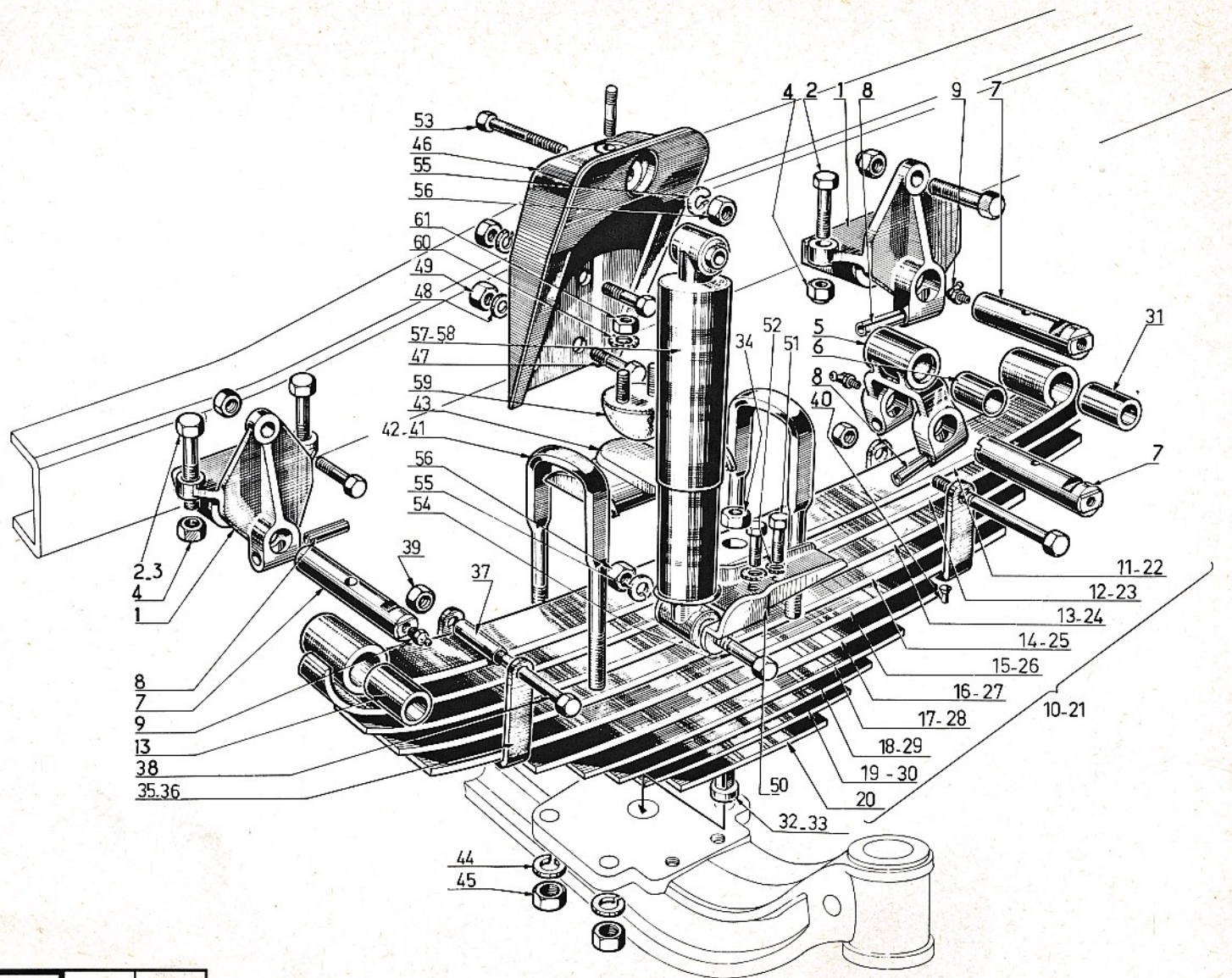

06	66	201	00	02
1	2	3	4	5



**06 66 201 00 03**

DÉSIGNATION PLANCHE : SERÉFÉRER AUX PAGES "SOMMAIRE"

PLATE DESIGNATION : REFER TO FLYLEAF

BILDBESCHRIFTUNG : SIEHE VORSATZBLÄTTER



6	7	8	9	10
1	61211492	SUPPORT	4	
2	61207265	BUTEE	4	
3	61803190	VIS LON 35	28	
4	61803191	VIS LON 40	4	
5	61801355	ECROU	32	
6	61666895	JUMELLE ASS	2	
7	615749C7	BAGUE	2	
8	61211494	AXE	6	
9	61820647	GOUPILLE	6	
10	61410502	GRAISSEUR	6	
11	61661719	RESSORT ASS	2	
12	61229944	BAGUE	4	
13	612145E7	LAME NO 1	2	
14	61214588	LAME NO 2	2	
15	61214589	LAME NO 3	2	
16	61214590	LAME NO 4	2	
17	61214591	LAME NO 5	2	
18	61214592	LAME NO 6	2	
19	61214593	LAME NO 7	2	
20	61214594	LAME NO 8	2	
21	61214595	LAME NO 9	2	
22	61214596	LAME NO 10	2	
23	61214604	BRIDE	4	
24	612146C3	BRIDE	4	
25	61207251	ENTRETOISE	8	

6	7	8	9	10
26	61207252	VIS	8	
27	61425007	ECROU	8	
28	61408374	RIVET	8	
29	61278870	RESSORT AUX, AS	2	
30	61214597	LAME NO 1	2	
31	61214598	LAME NO 2	2	
32	61214599	LAME NO 3	2	
33	61214600	LAME NO 4	2	
34	61214601	LAME NO 5	2	
35	61214605	BRIDE	4	
36	61214602	ETOQUIAU	2	
37	61520257	ECROU	2	
38	61218401	ETRIER	4	249
39	61211558	ETRIER	4	246
40	61218402	PLAQUE	2	249
41	61207268	PLAQUE	2	246
42	61207269	BRIDE	2	246
43	61218400	BRIDE	2	249
44	61815250	RONDELLE	8	
45	61207789	ECROU	8	
46	61118063	BUTEE	2	
47	61819954	GOUPILLE	4	

10	11
246	Châssis - P 6 Chassis - P 6 Chassis - P 6
249	Châssis - P 8 - P 8 R - T 8 R - P 9 Chassis - P 8 - P 8 R - T 8 R - P 9 Chassis - P 8 - P 8 R - T 8 R - P 9

10	11

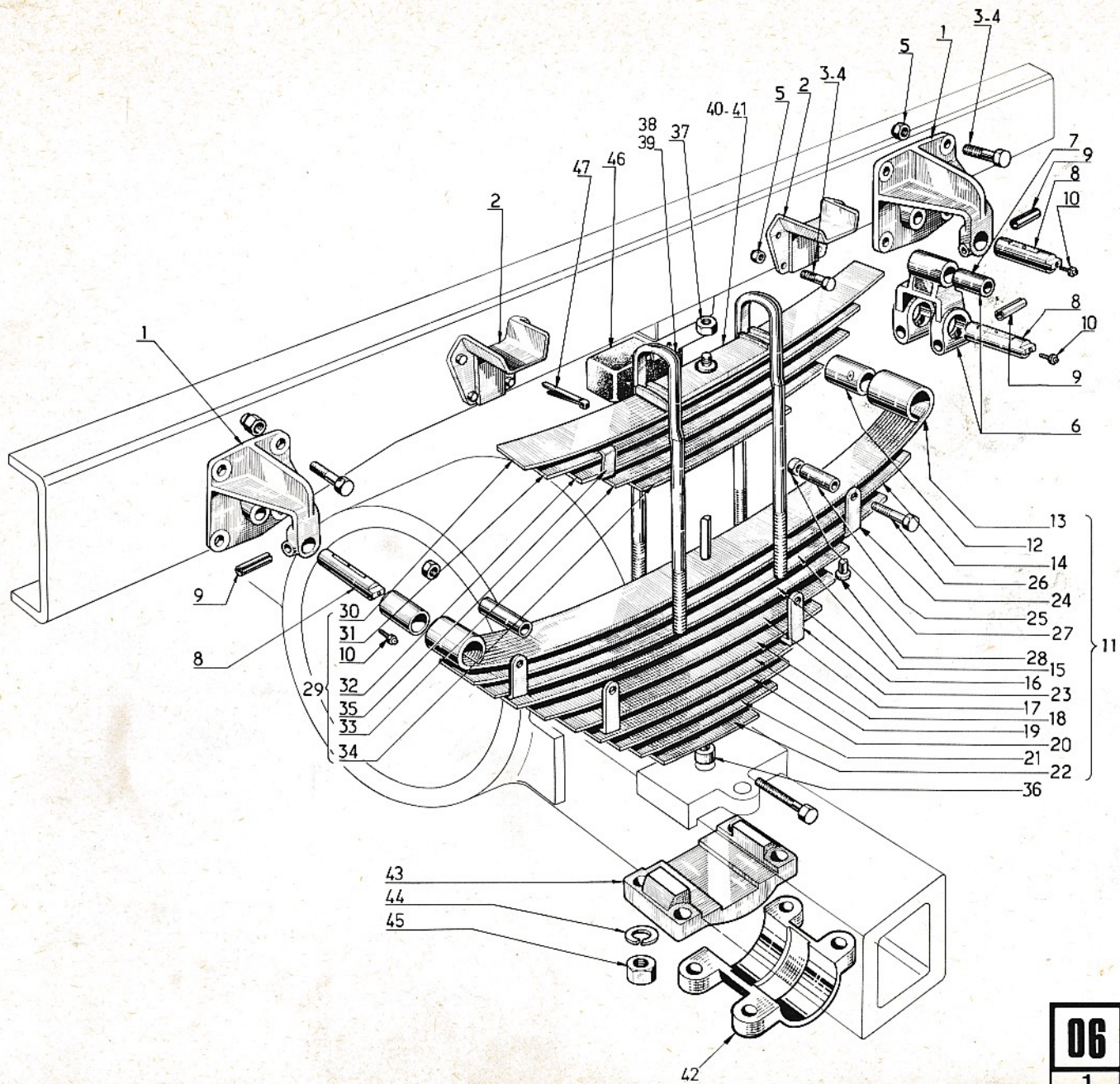

<b>06</b>	<b>66</b>	<b>201</b>	<b>00</b>	<b>03</b>
1	2	3	4	5

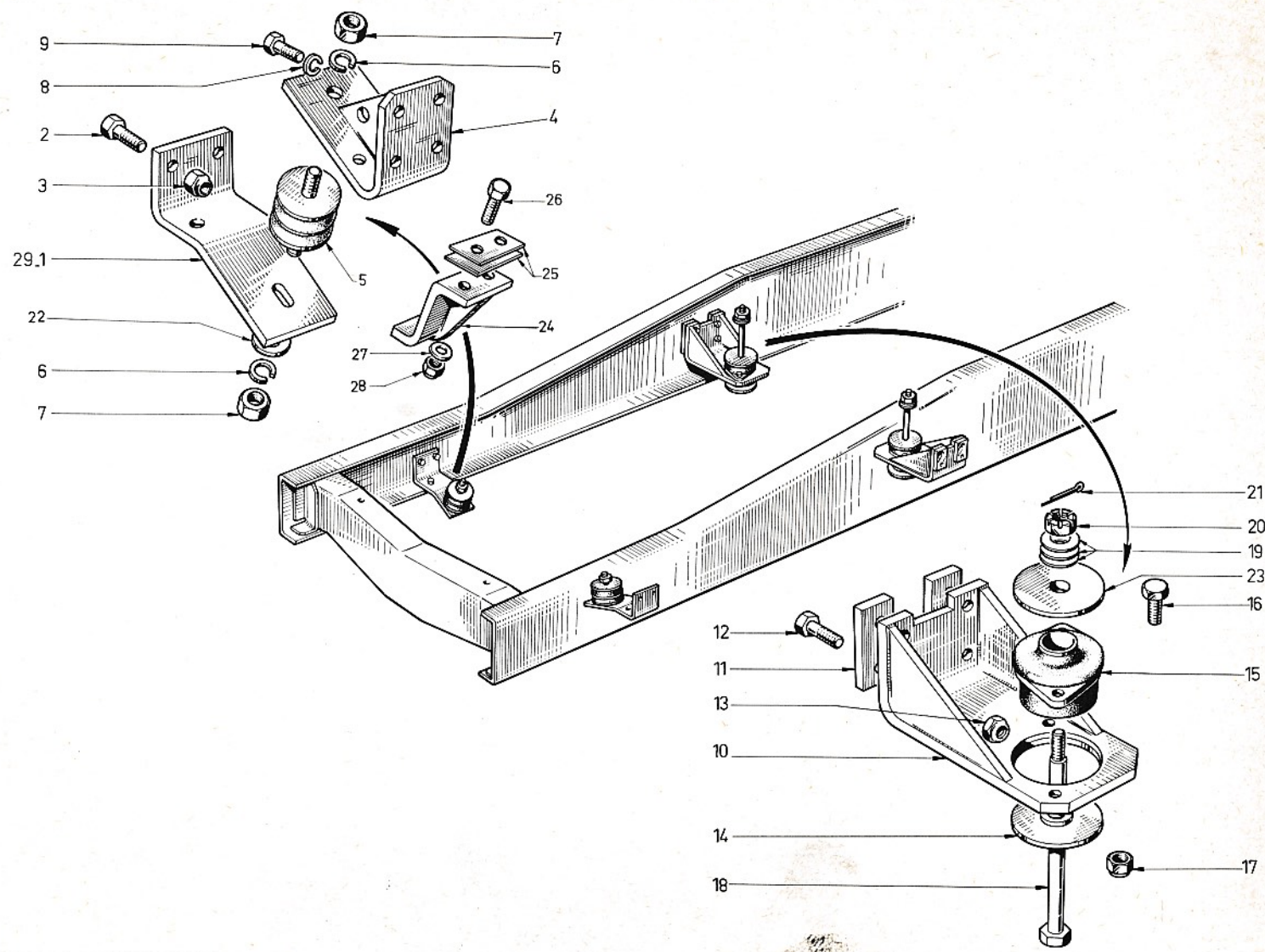

06	66	201	00	04
1	2	3	4	5

6	7	8	9	10
1	61228866	SUPPORT D	1	
2	61803190	VIS	4	
3	61801355	ECROU	4	
4	61227527	SUPPORT	2	
5	61235241	CAOUTCHOUC	2	
6	61815225	RONDELLE	4	
7	61225310	ECROU	4	
8	61815226	RONDELLE	8	
9	61803187	VIS	8	
10	61232538	SUPPORT	2	
11	61225933	CALE	4	
12	61803193	VIS	8	
13	61801355	ECROU	8	
14	61230305	RONDELLE	2	
15	61235170	CAOUTCHOUC	2	
16	61803149	VIS	4	
17	61801354	ECROU	4	
18	61225017	AXE	2	
19	61815007	RONDELLE		68
20	61520014	ECROU	2	
21	61819922	GOUPILLE	2	
22	61815057	RONDELLE	2	
23	61233150	RONDELLE	2	
24	61236462	LIMITEUR	2	
25	61231224	CALE		68

10	11
68	Quantités : au choix Quantities : as desired Mengen : nach Wahl

6	7	8	9	10
26	61803150	VIS	4	
27	61815005	RONDELLE	4	
28	61801354	ECROU	4	
29	61232893	SUPPORT G	1	

10	11